



 AN ISO 9001 : 2015 CERTIFIED COMPANY



ALLARK[®]
 Since 2003...



Interactive Panel Display
Writing Boards
Display Boards
Accessories

new

new



Manufactured By :

ALTON[®]
 marketing

www.altonmarketing.co.in



FOLLOW US ON

Stockist :

Unit No. 1941/42, Khan Compound,
 Off. Marve Road, Behind Malvani Church
 / St. Anthony High School, Chickoo Wadi
 Road, Malad (W), Mumbai- 400095.
 Email : altonmkg2003@gmail.com
 Customer Care No.: +91 84229 29745/
 98675 37378.
 GST No.: 27ACSPM6091K1ZT

This Catalog should not be reproduced as it is covered under Copyright Act.

IGBC



THE TRADE MARKS ACT, 1999
NSIC
 CERTIFIED CO.
 National Small Industries Corporation
 NSIC - MP - 1507



www.altonmarketing.co.in





P R O F I L E I N D E X



- ◆ Interactive Flat Panel Display
- ◆ Updown & Sliding Writing Boards
- ◆ Glass Writing Boards
- ◆ White Dry Wipe / Green Chalk Boards
- ◆ Display Boards
- ◆ Notice Boards
- ◆ Grooved Boards
- ◆ Stands & Accessories

ALLARK the name of Quality and Professional manufacturing in Writing and Display Boards for office, school land home, founded in 2003, committed to our policy of Honesty, High Speed, Top Quality, Continuously Innovation and Efficient Service and glad to invite you to be our value partner. We can offer high quality of Communication Boards & Accessory, Hardware Products such as Easels.

Corporating with **ALLARK**, We are one of the leading manufacturers of Board Products all over the India. You will find a total solution partner you never meet before.

ALLARK's a leading position of creating numerous valuable products; most of OEM/ODM/OBM big companies all over the India are our partners. We have big volume manufacturing capacity per day to distribute to our Distributors/Stockists in their respective markets.

Our Factory is located in Malad, Mumbai, We have sufficient and professional human resource to offer perfect service at all time. With a skilled manufacturing team, and a unique and typical R & D team we continuously introduce new products to suit Indian market. Over the years, we have been through changes of the Indian market. We can offer customers not only competitive costs but 'most favoured customers costs that allow customers to be most satisfied with high quality Products. We strictly execute our Quality Control System to maintain best quality level.

In 2008, we acquired **ISO 9001 : 2008** Certification upgraded to latest **9001 : 2015**. We have full experience in product and materials inspection and test. We are a total solution factory and only solution for you to enhance the cover value of your brand products in market place.

To be strong in competition, we continuously increase our production ability, efficiency and capacity to cost 'down Further more commit to create ,mo re product value and share to customers all the time. To develop employee's career different training program is undertaking in many field in order to grow our ability of production, R&D, Marketing and Management, We have the confidence that **ALLARK** may have your reliability and meet your satisfaction. For a complete review of what we can offer please refer to all pages or call our marketing staffs for further service. Join us as our partner and family.



■ Interactive Flat Panel Display	4-5	■ Felt / Fabric Pin Up Notice Boards	35
■ Manual Up Down Board	6	■ Combination Boards	36
■ Motorised Up Down Board	7	■ Double Sided Boards	37
■ Horizontal Sliding Board System	8	■ Double Sided Boards	38
■ Ceramic White Boards	9	■ Grooved Board / Door Covered Grooved Display Board / Golden Stand	39
■ Ceramic Green Boards	10	■ Perforated Boards	40
■ Magnetic White Boards	11	■ Letters & Figures Perforated Display Board	41
■ Magnetic Green Boards	12	■ Door Covered Notice Board	42
■ Non Magnetic White Boards	13	■ Sliding Glass Door Cover Board	43
■ Non Magnetic Green Boards	14	■ Key Boards	44
■ Ceramic / Magnetic / Non Magnetic White Boards	15	■ Laptop Table	45
■ Ceramic / Magnetic / Non Magnetic Green Board	16	■ Study Table & Kidz Board	46
■ Magnetic Graph Board	17	■ Lobby Information Board with Stand	47
■ Non Magnetic Graph Board	18	■ First Aid Box / Suggestion Box / Letter Box	48
■ Ceramic / Magnetic / Non Magnetic Board	19	■ Exhibition Display Boards	49
■ Pre laminated Both Sided White + Green Chalk Board	20	■ Dim Kit / Planner Boards	50
■ Pre laminated Both Sided White + Green Chalk Board	21	■ Flip Chart Board Stands / Three leg Stand / Wooden Stands	51
■ Ceramic / Magnetic / Non Magnetic White Board	22	■ Board Stands - Fixed Type / Revolving & Four Leg Stands	52
■ Ceramic / Magnetic / Non Magnetic Green Board	23	■ Fixed Type Movable Stands	53
■ Ceramic / Magnetic / Non Magnetic White Board	24	■ Lobby Board Stands	54
■ Ceramic / Magnetic / Non Magnetic Green Board	25	■ Board Accessories	55-56
■ Non Magnetic Glass Writing Board	26	■ Acrylic Products	57
■ Magnetic Glass Writing Board	27	■ Acrylic products	58
■ Felt Pin Up Notice Board	28	■ Sliding Glass Board Assembly Procedure	59
■ Fabric Pin Up Notice Board	29	■ Line Diagrams	60
■ Cork Pin Up Notice Board	30	■ Guide for Care & Maintenance of white Marker / Chalk Board	61
■ Felt / Fabric / Cork Pin up Notice Board	31	■ All Ark Boards Installed on Site	62
■ Felt / Fabric Pin Up Notice Board	32	■ Customised Board & Stands	63
■ Economical Felt / Fabric Pin Up Notice Board	33		
■ Felt / Fabric Pin Up Notice Board	34		



Interactive Flat Panel Display

The versatile 4K UHD interactive display bring more collaboration and student engagement to your classroom. Turn the display into digital whiteboard, share files in one touch, and use your favorite software all with your fingers and the press of a button. All Ark S75 Interactive display works in your world and lets you interact your way.

Superior Touch Experience

With All Ark S 75 state-the-art touch technology, Users can annotate with a writing stylus or fingers which is as natural as writing on papers.

Interaction made easy

All Ark S 75 Interactive display brings efficiency to your classes and teams so you can interact with ease, anytime. With a lightweight slim frame design, Windows system and built-in OS support, embedded tools and a personalized user interface, it's the perfect solution to seamless collaboration in school and in the office.

Interact with the whole group

All Ark S 75 Interactive display series supports up to 20 points of touch, allowing multiple users to interact at the same time. With smooth and responsive touch, anyone can take notes, write and draw on the screen, making the classroom a truly collaborative space.

Customize the interface to meet your needs.

Whether you need a display for your classroom or conference room, the All Ark S 75 Interactive display lets you easily change the screen theme and personalize the user interface on your built-in operating system. Keep the home screen simple while giving your team quick access to any tools they might need.



Product Features:

- ▶ Stunning 4K UHD resolution redefines clarity
- ▶ High accuracy touch screen.
- ▶ All-channel annotating.
- ▶ Built-in Android writing software with hand writing recognition and object recognition
- ▶ 4K Android system UI (OPS is also 4K). Three Launchers design for your choice.
- ▶ 4 screens mirroring
- ▶ 4 way Split Screen in Whiteboard
- ▶ 4 wireless device sharing simultaneously
- ▶ Screen Capture to save and email.
- ▶ Support auto turn off, Sleep timer and the other features.
- ▶ Support Audio only mode.
- ▶ Support wake up on HDMI, Wake up on Lan.
- ▶ Support HDCP2.2 (HDMI 1.4/2.0).
- ▶ 20 Points touch (Windows) 10 Points Writing (Android)



- Zero Bonding Technology
- Type-C Port
- 2 x 20W Speakers
- 450 nits Brightness
- Screen Recorder
- 7 MOHS Toughened Glass
- 6000 Hours Screen Life
- Anti Glare Screen
- Bluetooth Connectivity
- 1mm Writing Height
- 4K UHD Resolution
- App & Tool Lock Feature
- Reverse Screen Mirroring

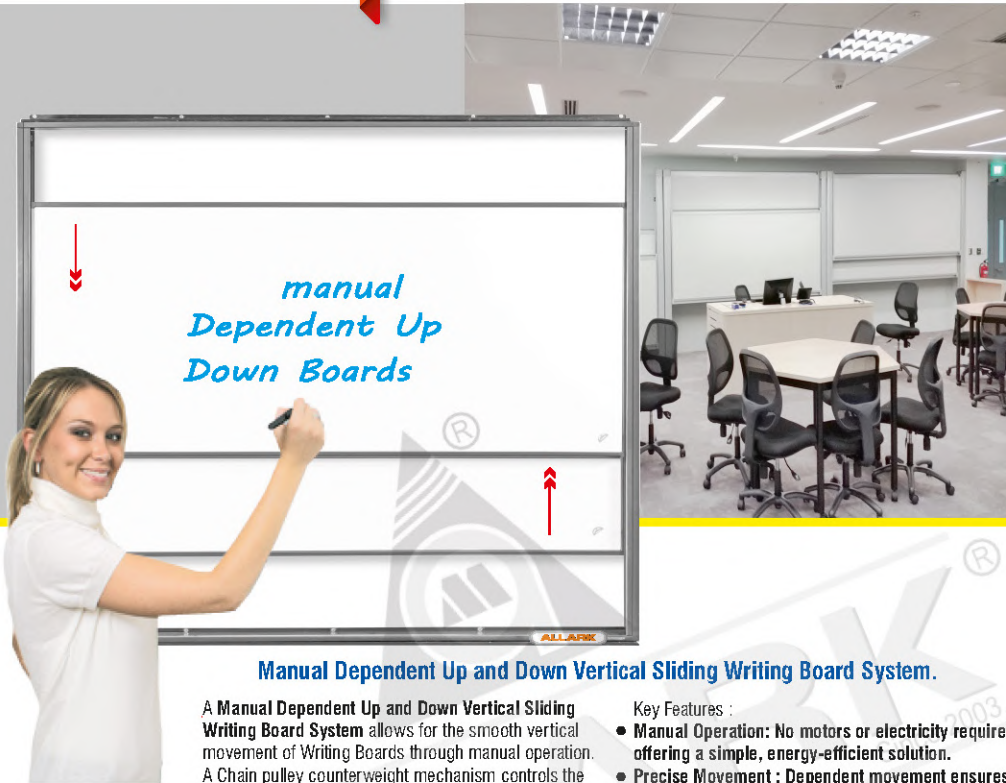

Manual Dependent Up and Down Vertical Sliding Writing Board System.

A Manual Dependent Up and Down Vertical Sliding Writing Board System allows for the smooth vertical movement of Writing Boards through manual operation. A Chain pulley counterweight mechanism controls the movement, ensuring stability and alignment. Two Writing boards are dependent each other and move on multi track Vertical Rail Sliding System. When one board is pulled down manually than the other board goes up. After fully written on one board, it can be pushed upwards and the lecturer can write on the second board which comes down. Structure made with heavy Aluminium frame with Plastic corner available in Silver Matte Brush Finish & Brown Glossy colour with wall mounting device.

- Key Features :
- **Manual Operation:** No motors or electricity required, offering a simple, energy-efficient solution.
 - **Precise Movement:** Dependent movement ensures the Writing Boards moves straight and smoothly. Ideal for Classrooms, offices, or other environments where height-adjustable Writing boards are needed, this system offers reliable performance and ease of use. **Writing Surfaces Available** :- Ceramic Steel, Magnetic & Non Magnetic White & Green.

All Size Available and can be customized also. Please Call or E-mail us for Sizes and any other Information.



Motorized Dependent Up and Down Vertical Sliding Writing Board System

A Motorized Dependent Up and Down Vertical Sliding Writing Board System provides automated vertical movement for Writing Boards. A Chain pulley counterweight mechanism to Powered by an Electric Motor, ensures smooth and precise up-and-down motion along a guided path. Two Writing boards are dependent each other and move on multi track Vertical Rail Sliding System. When one board is brought down by remote than the other board goes up. After fully written on one board, it can be automatically moved upwards by operating the remote and the lecturer can write on the second board. Structure made with heavy Aluminium frame with Plastic corner available in Silver Matte Brush Finish & Brown Glossy colour with wall mounting device.

- Key Features:
- **Motorized Control:** Allows easy adjustment with a remote.
 - **Smooth and Stable Movement:** The Chain Pulley mechanism ensures precise alignment.
 - **Safety Features:** Includes sensors and locking systems to prevent accidents. This system is ideal for modern work spaces, conference rooms, and educational Institutes, offering convenience, flexibility, and enhanced functionality for dynamic Writing Board needs. **Writing Surfaces Available** :- Ceramic Steel, Magnetic & Non Magnetic White & Green.

All Size Available and can be customized also. Please Call or E-mail us for Sizes and any other Information.

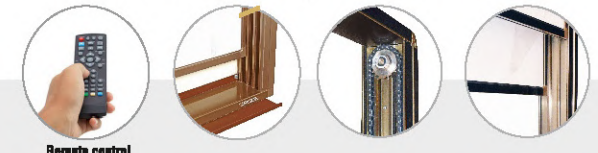



A better choice Across the Board ! Get the maximum use out of your presentation and instruction space.

Horizontal Sliding Board System

- ▶ Horizontal Sliding Boards save wall space and add functional board surface. Customizable boards feature panels that slide on a smooth track system.
- ▶ Lightweight core material and precise alignment of the tracks ensure easy operation.
- ▶ Choose from two-, three-, or four-track systems.
- ▶ Panels are 4'H and from 60" to 20' W. Available with Non magnetics, magnetics and ceramic marker board or any Stackable surface.
- ▶ Framed with heavy gauge anodized aluminum tubing.
- ▶ Map rail and accessory tray included.

Writing Surfaces Available :- Ceramic Steel, Magnetic & Non Magnetic White & Green.
All Size Available and can be customized also. Please Call or E-mail us for Sizes and any other Information.



Astel Series



- ▶ With its smart, premium enamel coated surface, the All Ark Vitreous Enamel Dry Wipe Board is the super tough & Superior Quality Writing Board.
- ▶ Popularly known as Vitreous Enamel ceramic Writing surface gives stylish & Silky solution for capturing action points and ideas in busy & professional environments.
- ▶ Thickness of the Surface is 0.55 mm is Durable for hard-wearing & is totally scratch proof and chip-resistant, making the board more ideal for Intensive use. With an outstanding 25 years surface warranty (subject to normal use), this enamel board is built to last for a longer time. You can purchase this board With total confidence.
- ▶ Semi Matte Magnetic Surface offers dual-purpose Projection cum Writing, Attracts Magnets so one can use magnetic Buttons or Magnetic Push Pins to attach printed sheets on the surface of the board while illustrating.
- ▶ Durable with its tough, anodized finish, the aluminum frame can withstand everyday wear and tear and stay looking good forever.
- ▶ Day-to-day cleaning with a Standard Magnetic Duster/ Erasers whilst a good clean Surface, Proper maintenance of the Board will ensure surfaces remain in Tip-top condition with no grease or ghost image and you can be sure of communicating a clear, professional message time after time.
- ▶ Following The instructions provided, any persons can manage this task easily and safely install the board on the wall using spares supplied inside each board.
- ▶ Pen tray can be purchased separately, so you can keep a selection of all coloured Marker close to hand.

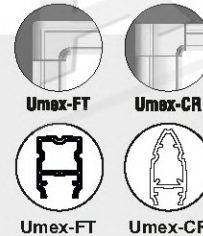

SIZE (MM) APPROX.	SIZE (MM) APPROX.	SIZE (MM) APPROX.
300X450	600X1500	1200X3000
300X600	600X1800	1200X3600
450X600	900X1200	—
450X900	1200X1200	—
600X600	1200X1500	—
600X900	1200X1800	—
600X1200	1200X2400	—



Astel Series

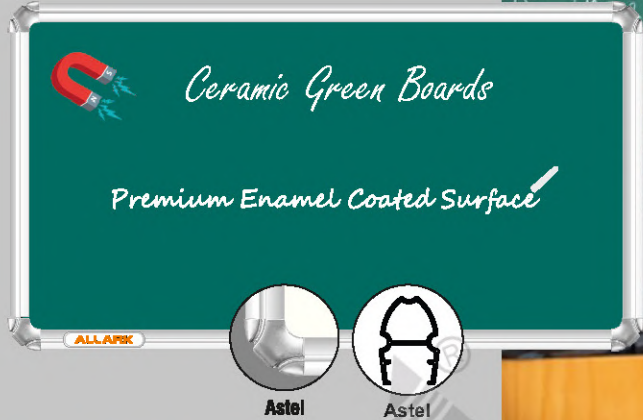

Astel Series



Ceramic Green Boards

- ▶ With its smart, premium enamel coated surface, the All Ark Vitreous Enamel Green Chalk Board is the Super Tough & Superior Quality Writing Board.
- ▶ Popularly known as Vitreous Enamel Writing surface gives stylish & Smooth Experience and Evolves Less Dust while Writing.
- ▶ Thickness of the Surface is 0.56 mm is Durable for hard-wearing & is totally scratch proof and chip-resistant, making the board more ideal for intensive use. With an outstanding 25 years surface warranty (subject to normal use), this enamel board is built to last for a longer time. You can purchase this board With total confidence.
- ▶ Attracts Magnets so one can use magnetic Buttons or Magnetic Push Pins to attach printed sheets on the surface of the board while illustrating.
- ▶ Durable with its tough, anodized finish, the aluminum frame can withstand everyday wear and tear and stay looking good forever.
- ▶ Day-to-day cleaning with a Standard Magnetic Duster/ Erasers whilst a good clean Surface, Proper maintenance of the Board will ensure surfaces remain in Tip-top condition with no ghost images and you can be sure of communicating a clear messages time after time.
- ▶ Following The instructions provided, any persons can manage this task easily and safely install the board on the wall using spares supplied inside each Board.
- ▶ Pen tray can be purchased separately, so you can keep a selection of all coloured Chalks close to hand.

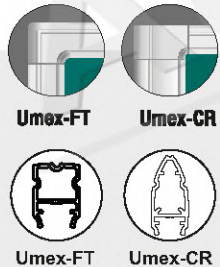

SIZE (MM) APPROX.	SIZE (MM) APPROX.	SIZE (MM) APPROX.
300X450	600X1500	1200X3000
300X600	600X1800	1200X3600
450X600	900X1200	—
450X900	1200X1200	—
600X600	1200X1500	—
600X900	1200X1800	—
600X1200	1200X2400	—

Magnetic White Boards

- ▶ With its premium, Triple Acrylic Resin Coated steel surface, ALL ARK Astel Magnetic white Steel Drywipe Board is both stylish and durable.
- ▶ This dual-purpose drywipe writing board and magnetic notice board is perfect for personal workstations, Offices, Cabins, Institutions or break-out areas in busy, professional environments. Attracts Magnets so one can use magnetic Buttons or Magnetic Push Pins to attach printed sheets on the surface of the board while illustrating.
- ▶ Thickness of the magnetic steel surface being 0.30 mm is chip resistant, making the ALL ARK Board ideal for frequent use.
- ▶ The clean smooth, contemporary Surface gives advantages for excellent quality writing & will speak volumes about the image of your company.
- ▶ Day-to-day cleaning with a Standard Magnetic Duster/ Erasers whilst a good clean Surface, Good Quality marker pens & proper maintenance of the Board will ensure surfaces remain in tip-top condition with no grease or ghost Images left behind.
- ▶ Durable with its tough, anodized finish, the aluminum frame can withstand everyday wear and tear and stay looking good forever.
- ▶ Following the instructions provided, any persons can manage this task easily and safely install the board on the wall using spares supplied inside each board.
- ▶ Pen tray can be purchased separately, so you can keep a selection of all coloured Makers close to hand.

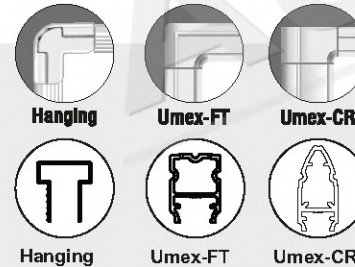

SIZE (MM) APPROX.	SIZE (MM) APPROX.	SIZE (MM) APPROX.
300X300	600X1500	1200X1200
300X450	600X1800	1200X1500
300X600	900X900	1200X1800
450X800	900X1200	1200X2400
450X900	900X1500	1200X3000
600X600	900X1800	1200X3600
600X900	900X2400	—
600X1200	900X3000	—



Astel Series



Astel

Astel

Magnetic Green Boards

- With its premium, Triple Acrylic Resin Coated steel surface, ALL ARK Astel Magnetic Green Chalk writing Steel Board is both stylish and durable.
- This dual-purpose writing board and magnetic notice board is perfect for Schools, Institutions, Private Tuitions in busy, professional environments. Attracts Magnets so one can use magnetic Buttons or Magnetic Push Pins to attach printed sheets on the surface of the board while illustrating.
- Thickness of the magnetic steel surface being 0.30 mm is chip resistant, making the ALLARK Board ideal for frequent use.
- The clean smooth, contemporary Surface gives advantages for excellent quality writing & evolves less dust while writing with Chalks..
- Day-to-day cleaning with a Standard Chalk Duster whilst a good clean Surface, Good Quality Dustless Chalks & Proper maintenance of the Board will ensure surfaces remain in tip-top condition with no ghost images left behind.
- Durable with its tough, anodized finish, the aluminum frame can withstand everyday wear and tear and stay looking good forever.
- Following the instructions provided, any persons can manage this task easily and safely install the board on the wall using spares supplied inside each board.
- Pen tray can be purchased separately, so you can keep a selection of all coloured Chalks close to hand.



Hanging

U-mex-FT

U-mex-CR

SIZE (MM) APPROX.	SIZE (MM) APPROX.	SIZE (MM) APPROX.
300X300	600X1500	1200X1200
300X450	600X1800	1200X1500
300X600	900X900	1200X1800
450X800	900X1200	1200X2400
450X900	900X1500	1200X3000
600X600	900X1800	1200X3600
600X900	900X2400	—
600X1200	900X3000	—



Hanging



U-mex-FT



U-mex-CR

Astel Series

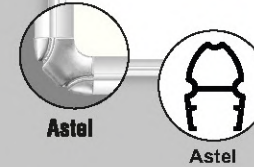
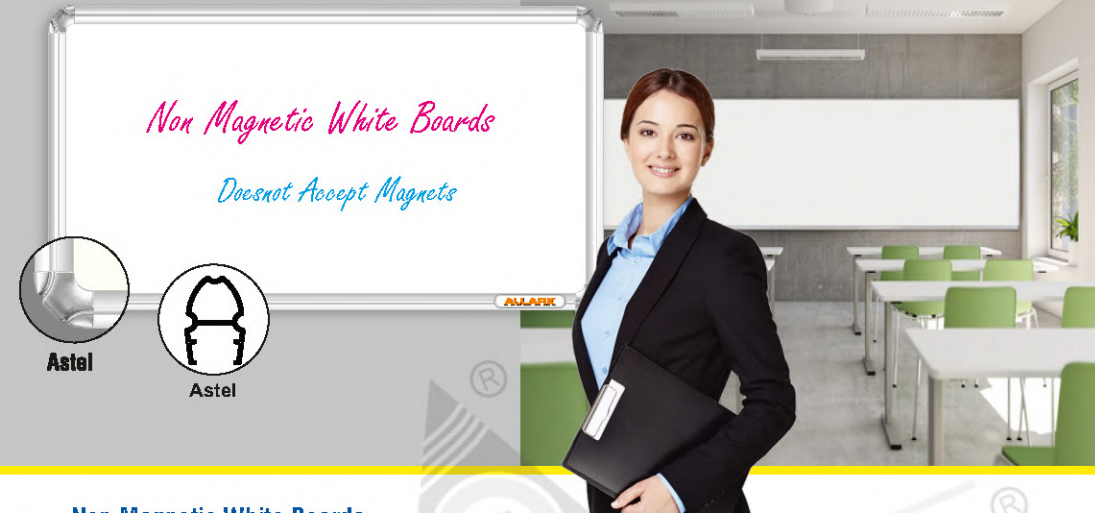

Astel

Astel

Non Magnetic White Boards

- With its modern, aluminium frame & Chrome Plated Corners, the tough surface, of the new ALL ARK Astel Extra Melamine Drywipe Board is both smart and economical.
- This drywipe board is the practical choice for individual workstations or at home where wall space is limited. Leave messages, write notes or list priority tasks and get yourself organized for the day ahead.
- The durable, melamine surface is chip-resistant & is ideal for general use & does not attract Magnets.
- Day-to-Day cleaning with a standard Non-Magnetic Duster/Erasers or with wet cloth whilst a good clean surface. Good Quality Marker Pens & proper maintenance of the board will ensure surfaces remain in tip-top condition with no grease or ghost images left behind.
- Durable with its tough, anodized finish, the aluminum frame can withstand everyday wear and tear and stay looking good forever.
- Following the instructions provided, any person can manage this task easily and safely install the board on the wall using spares supplied inside each board.
- Pen tray can be purchased separately, so you can keep a selection of drywipe markers close to hand.



Hanging

U-mex-FT

U-mex-CR

SIZE (MM) APPROX.	SIZE (MM) APPROX.	SIZE (MM) APPROX.
300X300	600X1500	1200X1500
300X450	600X1800	1200X1800
300X600	900X900	1200X2400
450X800	900X1200	1200X3000
450X900	900X1500	1200X3600
600X600	900X1800	—
600X900	900X2400	—
600X1200	1200X1200	—



Hanging



U-mex-FT



U-mex-CR



Astel Series



Non Magnetic Green Boards

- > With its modern, aluminium frame & Chrome Plated Corners, the tough non magnetic surface of the new ALL ARK Astel Melamine Chalk Board is both smart and economical.
- > This Green chalk board is the practical choice for individuals at home, at Schools, Institutions Etc....
- > The durable, melamine surface is totally Scratch proof and Chip-resistant and evolves less dust while writing with Chalks.
- > Surface is ideal for general use & does not attract Magnets.
- > Day-to-day writing can be easy earsed with a Standard Non-Magnetic Duster or with a wet cloth for a good clean Surface, Good Quality Dustless Chalks & proper maintenance of the Board will ensure surfaces remain in tip-top condition with no ghost images left behind.
- > Durable with its tough, anodized finish, the aluminum frame can withstand everyday wear and tear and slay looking good forever.
- > Following the instructions provided, any persons can manage this task easily and safely install the board on the wall using spares supplied inside each board.
- > Pen tray can be purchased separately, so you can keep a selection of all coloured Chalks close to hand.

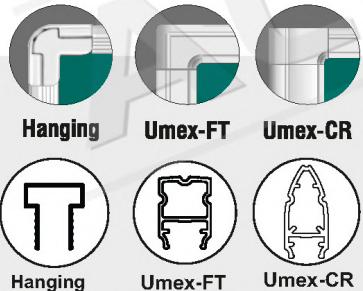

SIZE (MM) APPROX.	SIZE (MM) APPROX.	SIZE (MM) APPROX.
300X300	600X1500	1200X1500
300X450	600X1800	1200X1800
300X600	900X900	1200X2400
450X600	900X1200	1200X3000
450X900	900X1500	1200X3600
600X600	900X1800	---
600X900	900X2400	---
600X1200	1200X1200	---

Eco Astel Series

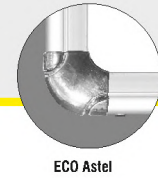

CERAMIC WHITE BOARD

- > Premium Enamel coated Surface. Thickness of the Surface is 0.56mm.
- > Ceramic White Board can be used for writing cum OHP Projection Screen, also attracts magnets, Magnetic Display Folders etc.
- > Can be utilized as Smart Board with attachment of Smart Board Kit.
- > 25 Years Surface Warranty. Scratch & Stain Resistant.

MAGNETIC WHITE BOARD

- > Triple Acrylic Resin Coated Steel Surface. Thickness of the Surface is 0.40mm.
- > High quality, durable marker board. Also attracts magnets, Magnetic Display Folders etc.
- > Smooth surface and glossy with proper hardness.
- > Can be used to display notices with the help of Magnetic Buttons/ Magnetic Push Pins.

NON-MAGNETIC WHITE BOARD

- > Non-Magnetic Board offers a smooth writing platform & is very reliable.
- > The basic raw material is paper based laminate coated with melamine therefore ink absorption of the marker ink is very less.
- > We have developed such sheet from our past experience which gives better writing & erasing.

Following the instructions provided, any persons can manage this task easily and safely install the board on the wall using spares supplied inside each board.



CERAMIC SIZES (MM) APPROX.		MAGNETIC SIZES (MM) APPROX.			NON MAGNETIC SIZES (MM) APPROX.		
300X450	900X1200	300X300	600X1800	1200X1800	300X300	600X1800	1200X2400
300X600	1200X1200	300X450	900X900	1200X2400	300X450	900X900	1200X3000
450X600	1200X1500	300X600	900X1200	1200X3000	300X600	900X1200	1200X3600
450X900	1200X1800	450X600	900X1500	1200X3600	450X600	900X1500	---
600X600	1200X2400	450X900	900X1800	---	450X900	900X1800	---
600X900	1200X3000	600X600	900X2400	---	600X600	900X2400	---
600X1200	1200X3600	600X900	900X3000	---	600X900	1200X1200	---
600X1500	---	600X1200	1200X1200	---	600X1200	1200X1500	---
600X1800	---	600X1500	1200X1500	---	600X1500	1200X1800	---



Eco Astel Series

Ceramic Green Board



Magnetic Green Board



Non Magnetic Green Board

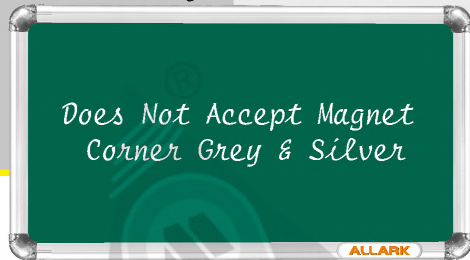

Astel Series

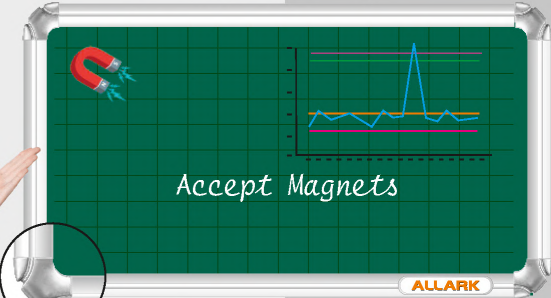

Astel



Astel

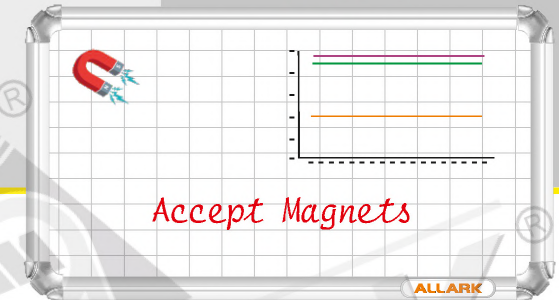

CERAMIC GREEN BOARD

- Maximum refraction makes board viewable easily from all corners of the classroom.
- Deep green colour makes fantastic contrast, make board visible easily even from last row of the classroom.
- Creates negligible chalk dust providing clean classroom.
- 25 Years Surface Warranty.

NON-MAGNETIC GREEN BOARD

- The basic raw material is paper based laminate coated with melamine.
- The Scratch Proof surface works same as glass board but at economy.
- We have developed such sheet from our past experience which gives better writing & erasing.
- In addition to this if you purchase from standard company, which can offer after sales service.

MAGNETIC GREEN BOARD

- Triple Resin Coated Steel Surface. Thickness of the Surface is 0.40mm.
- High quality, durable marker board. Also attracts magnets, Magnetic Display Folders etc.
- Smooth surface and proper hardness evokes less dust while writing.
- Can be used to display notices with the help of Magnetic Buttons/ Magnetic Push Pins.

Following the instructions provided, any persons can manage this task easily and safely install the board on the wall using spares supplied inside each board.

Magnetic Graph Board

- With its premium, Triple Acrylic Resin Coated steel surfaces, ALLARK ASTEL Magnetic Writing Boards are both stylish and durable.
- This dual-purpose writing board and magnetic notice board is perfect for Schools, Institutions, Private Tuitions in busy, professional environments. Attracts Magnets so one can use magnetic Buttons or Magnetic Push Pins to attach printed sheets on the surface of the board while illustrating.
- Thickness of the magnetic steel surface being 0.40 mm is chip resistant, making the ALLARK Board ideal for frequent use.
- The clean smooth, contemporary Surface gives advantages for excellent quality writing.
- 5 cms X 5cms graph available for writing and drawing on both the surfaces.
- Day-to-day cleaning with a Standard Chalk Board Duster for green chalk surface & Standard Magnetic Duster/ Erasers used for a white marker surface, whilst a good clean Surface. Usage of Good Quality Chalks / marker pens & Proper maintenance of the Board will ensure surfaces remain in tip-top condition with no ghost images left behind.
- Durable with its tough, anodized finish, the aluminum frame can withstand everyday wear and tear and stay looking good forever.
- Following the instructions provided, any persons can manage this task easily and safely install the board on the wall using spares supplied inside each board.
- Pen tray can be purchased separately, so you can keep a selection of all coloured Chalks close to hand.



Eco Astel

CERAMIC SIZES (MM) APPROX.		MAGNETIC SIZES (MM) APPROX.			NON MAGNETIC SIZES (MM) APPROX.		
300X450	900X1200	300X300	600X1800	1200X1800	300X300	600X1800	1200X2400
300X600	1200X1200	300X450	900X900	1200X2400	300X450	900X900	1200X3000
450X600	1200X1500	300X600	900X1200	1200X3000	300X600	900X1200	1200X3600
450X900	1200X1800	450X600	900X1500	1200X3600	450X600	900X1500	---
600X600	1200X2400	450X900	900X1800	---	450X900	900X1800	---
600X900	1200X3000	600X600	900X2400	---	600X600	900X2400	---
600X1200	1200X3600	600X900	900X3000	---	600X900	1200X1200	---
600X1500	---	600X1200	1200X1200	---	600X1200	1200X1500	---
600X1800	---	600X1500	1200X1500	---	600X1500	1200X1800	---



Umax-FT



Umax-CR



Umax-FT



Umax-CR

SIZE (MM) APPROX.	SIZE (MM) APPROX.	SIZE (MM) APPROX.
300X300	600X1500	1200X1200
300X450	600X1800	1200X1500
300X600	900X900	1200X1800
450X600	900X1200	1200X2400
450X900	900X1500	1200X3000
600X600	900X1800	1200X3600
600X900	900X2400	---
600X1200	900X3000	---



Astel Series

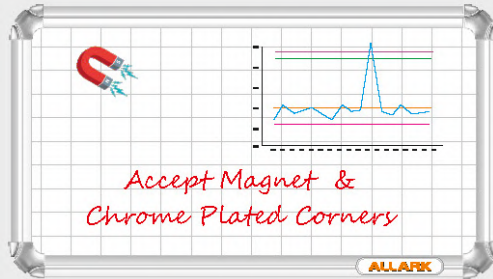
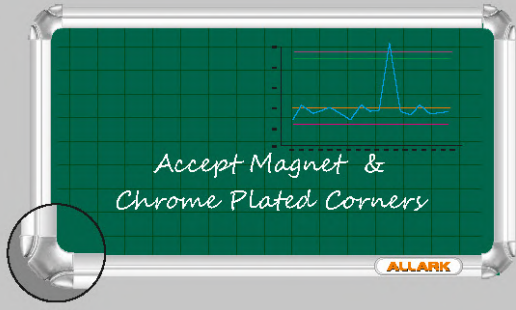

Astel



Astel

Non Magnetic Graph Board

- With its modern, aluminium frame & Chrome Plated Corners, the tough surface, of the new ALLARK ASTEL Extra Melamine Chalk & Dry wipe Board is both smart and economical.
- This Green Chalk Board & drywipe board is the practical choice for individual workstations or at home where wall space is limited. Leave messages, write notes or list priority tasks and get yourself organized for the day ahead.
- The durable, melamine surface is chip-resistant & is ideal for general use & does not attract Magnets.
- 5cms X 5cms graph available for writing and drawing on both the surfaces.
- Day-to-day cleaning with a Standard Chalk Duster for green chalk surface & Standard Non-Magnetic Duster/ Erasers used for a white marker surface, whilst a good clean Surface. Usage of Good Quality Chalks / marker pens & Proper maintenance of the Board will ensure surfaces remain in tip-top condition with no ghost images left behind.
- Durable with its tough, anodized finish, the aluminum frame can withstand everyday wear and tear and stay looking good forever.
- Following the instructions provided, any persons can manage this task easily and safely Install the board on the wall using spares supplied inside each board.
- Pen tray can be purchased separately, so you can keep a selection of all coloured chalks / drywipe markers close to hand.



Umex-FT



Umex-CR

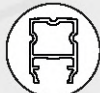

Umex-FT



Umex-CR

SIZE (MM) APPROX.	SIZE (MM) APPROX.	SIZE (MM) APPROX.
300X300	600X1500	1200X1200
300X450	600X1800	1200X1500
300X600	900X900	1200X1800
450X600	900X1200	1200X2400
450X900	900X1500	1200X3000
600X600	900X1800	1200X3600
600X900	900X2400	—
600X1200	900X3000	—

Hanging Series



Hanging

Ceramic White Board



Hanging

Magnetic Green Chalk Board



Hanging

Non Magnetic Green chalk Board



Hanging

Non Magnetic White Board

Ceramic, Magnetic & Non Magnetic Board

CERAMIC BOARD

- Ceramic coated imported steel surface.
- Thickness of the surface being 0.56mm, is totally crack proof/scratch resistance and attracts magnets.
- Available in White colour for writing with markers & Green colour for writing with Chalks.

MAGNETIC BOARD

- Triple acrylic resin coated imported steel surface.
- Thickness of the surface being 0.40mm, is totally crack proof and attracts magnets.
- Available in White colour for writing with markers & Green colour for writing with Chalks.

NON MAGNETIC BOARD

- Have smooth economical non magnetic extra melamine coated writing surface. Does not attracts magnets.
- Images goes on wet, dries instantly and is removed easily with a standard non magnetic duster.
- Available in White colour for writing with markers & Green colour for writing with Chalks.



Hanging

CERAMIC SIZE (MM)APPROX.	MAGNETIC SIZE (MM)APPROX.		NON MAGNETIC SIZE (MM)APPROX.	
600X900	300X300	600X1200	1200X1500	300X300 600X1200 1200X1500
900X1200	300X450	600X1800	1200X1800	300X450 600X1800 1200X1800
1200X1200	300X600	900X900	1200X2400	300X600 900X900 1200X2400
1200X1500	450X600	900X1200	—	450X600 900X1200 —
1200X1800	460X900	900X1600	—	460X900 900X1600 —
—	600X600	900X1800	—	600X600 900X1800 —
—	600X900	1200X1200	—	600X900 1200X1200 —



Eco Hanging Series

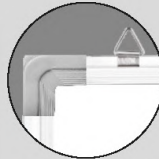

Front Side Board



Back Side Board

Eco Astel Series



Front Side Board



Back Side Board

- ▶ Both Side White + Green Pre-laminated Board with Eco Hanging Frame.
- ▶ Dual-Sided Lamination: Both sides are paper laminated white for dry-erase markers and green for chalk offering smooth, versatile writing surfaces.
- ▶ Easy to Clean: Both sides wipe clean easily, resisting stains and ghosting from markers or chalk.
- ▶ Hanging Frame : Comes with a sturdy yet lightweight frame, allowing for easy wall mounting and repositioning.
- ▶ Smooth Writing Experience: High-gloss white for markers and non-glare matte green for chalk ensure clear, effortless writing.
- ▶ Versatile: Suitable for home use.
- ▶ Cost-Effective: Combines both whiteboard and chalkboard functions, reducing the need for two separate boards.
- ▶ This board offers a functional and durable solution for various settings with its high-quality paper-laminated surfaces.

- ▶ Both Side White + Green Prelaminated Board with Eco Astel Frame.
- ▶ Dual-Sided Lamination: Both sides are paper laminated white for dry-erase markers and green for chalk offering smooth, versatile writing surfaces.
- ▶ Easy to Clean: Both sides wipe clean easily, resisting stains and ghosting from markers or chalk.
- ▶ Eco Astel Frame: Comes with a sturdy yet lightweight frame, allowing for easy wall mounting and repositioning.
- ▶ Smooth Writing Experience: High-gloss white for markers and non-glare matte green for chalk ensure clear, effortless writing.
- ▶ Versatile: Suitable for home use.



Hanging

Pre Laminated Both side White Board - Hanging SIZES (MM) APPROX.		
300X300	600X1800	1200X2400
300X450	900X900	---
300X600	900X1200	---
450X600	900X1500	---
450X900	900X1800	---
600X600	900X2400	---
600X900	1200X1200	---
600X1200	1200X1500	---
600X1500	1200X1800	---



Eco Astel

Pre Laminated Both side Green Board - Hanging SIZES (MM) APPROX.		
300X300	600X1800	1200X2400
300X450	900X900	---
300X600	900X1200	---
450X600	900X1500	---
450X900	900X1800	---
600X600	900X2400	---
600X900	1200X1200	---
600X1200	1200X1500	---
600X1500	1200X1800	---



UMEX-CR SERIES



Ceramic White Board



Magnetic White Board

UMEX-CR SERIES



Ceramic Green Board



Magnetic Green Board



Chrome Plated Corners
Umex-CR

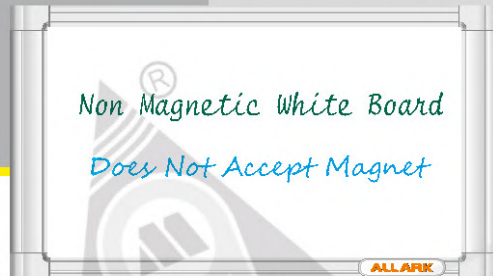

Non Magnetic White Board



Umex Cr



Chrome Plated Corners
Umex-CR



Non Magnetic Green Board



Umex Cr

CERAMIC WHITE BOARD

- Premium enamel coated surface with thickness of 0.56 mm. Is durable for hard-wearing & is totally scratch proof and chip-resistant making the board more ideal for intensive use. With an outstanding 25years surface warranty (subject to normal use), this enamel board is built to last for a longer time. Semi matte magnetic surface offers dual-purpose projection cum writing.

MAGNETIC WHITE BOARD

- Premium triple acrylic resin coated steel surface with thickness of 0.40 mm. Is chip resistant, making the board ideal for frequent use. The clean smooth, contemporary surface gives advantages for excellent quality writing & will speak volumes about the image of your company. Day-to-Day cleaning with a standard magnetic duster/erasers whilst a good clean surface, good quality marker pens & proper maintenance of the board will ensure remain in tip top condition with no grease or ghost images left behind.

NON-MAGNETIC WHITE BOARD

- The durable, melamine surface is chip-resistant & is ideal for general use & does not attracts magnets. Durable with its tough, anodized finish the aluminium frame can withstand everyday wear and tear and stay looking good forever.

CERAMIC GREEN BOARD

- Premium enamel coated surface with thickness of 0.56 mm., the AllArk UMEX-CR Magnetic Enamel Green Chalk Board is durable for hard-wearing & is totally scratch proof and chip-resistant making the board more ideal for intensive use. With an outstanding 25years surface warranty (subject to normal use), this enamel board is built to last for a longer time. Semi matte magnetic surface offers dual purpose projection cum writing.

MAGNETIC GREEN BOARD

- Premium triple acrylic resin coated steel surface with thickness of 0.40 mm. Is chip resistant, making the board ideal for frequent use. The clean smooth, contemporary surface gives advantages for excellent quality writing & will speak volumes about the image of your company. Day-to-Day cleaning with a standard magnetic duster/erasers whilst a good clean surface, good quality marker pens & proper maintenance of the board will ensure remain in tip top condition with no grease or ghost images left behind.

NON-MAGNETIC GREEN BOARD

- The durable, melamine surface is chip-resistant & is ideal for general use & does not attracts magnets. Durable with its tough, anodized finish the aluminium frame can withstand everyday wear and tear and stay looking good forever.

CERAMIC BOARD

SIZE (MM) APPROX.	SIZE (MM) APPROX.
600X900	1200X1800
600X1200	1200X2400
600X1800	1200X3000
900X1200	1200X3200
1200X1500	---

MAGNETIC / NON MAGNETIC BOARD

SIZE (MM) APPROX.	SIZE (MM) APPROX.	SIZE (MM) APPROX.
600X900	900X1200	1200X2400
600X1200	900X1500	1200X3000
600X1800	900X1800	1200X3200
900X900	1200X1500	---
900X1200	1200X1800	---

CERAMIC BOARD

SIZE (MM) APPROX.	SIZE (MM) APPROX.
600X900	1200X1800
600X1200	1200X2400
600X1800	1200X3000
900X1200	1200X3200
1200X1500	---

MAGNETIC / NON MAGNETIC BOARD

SIZE (MM) APPROX.	SIZE (MM) APPROX.	SIZE (MM) APPROX.
600X900	900X1200	1200X2400
600X1200	900X1500	1200X3000
600X1800	900X1800	1200X3200
900X900	1200X1500	---
900X1200	1200X1800	---

UMEX-FT SERIES



Ceramic White Board



Magnetic White Board



Non Magnetic White Board



Chrome Plated Corners
Umex-FT



Umex FT



Ceramic Green Board



Magnetic Green Board



Non Magnetic Green Board



Chrome Plated Corners
Umex-FT



Umex FT

CERAMIC WHITE BOARD

- Premium enamel coated surface with thickness of 0.56 mm. Is durable for hard-wearing & is totally scratch proof and chip-resistant making the board more ideal for intensive use. With an outstanding 25years surface warranty (subject to normal use), this enamel board is built to last for a longer time. Semi matte magnetic surface offers dual-purpose projection cum writing.

MAGNETIC WHITE BOARD

- Premium triple acrylic resin coated steel surface with thickness of 0.40 mm. Is chip resistant, making the board ideal for frequent use. The clean smooth, contemporary surface gives advantages for excellent quality writing & will speak volumes about the image of your company. Day-to-Day cleaning with a standard magnetic duster/erasers whilst a good clean surface, good quality marker pens & proper maintenance of the board will ensure remain in tip top condition with no grease or ghost images left behind.

NON-MAGNETIC WHITE BOARD

- The durable, melamine surface is chip-resistant & is ideal for general use & does not attracts magnets. Durable with its tough, anodized finish the aluminium frame can withstand everyday wear and tear and stay looking good forever.

CERAMIC GREEN BOARD

- Premium enamel coated surface with thickness of 0.56 mm., the AllArk UMEX-CR Magnetic Enamel Green Chalk Board is durable for hard-wearing & is totally scratch proof and chip-resistant making the board more ideal for intensive use. With an outstanding 25years surface warranty (subject to normal use), this enamel board is built to last for a longer time. Semi matte magnetic surface offers dual purpose projection cum writing.

MAGNETIC GREEN BOARD

- Premium triple acrylic resin coated steel surface with thickness of 0.40 mm. Is chip resistant, making the board ideal for frequent use. The clean smooth, contemporary surface gives advantages for excellent quality writing & will speak volumes about the image of your company. Day-to-Day cleaning with a standard magnetic duster/erasers whilst a good clean surface, good quality marker pens & proper maintenance of the board will ensure remain in tip top condition with no grease or ghost images left behind.

NON-MAGNETIC GREEN BOARD

- The durable, melamine surface is chip-resistant & is ideal for general use & does not attracts magnets. Durable with its tough, anodized finish the aluminium frame can withstand everyday wear and tear and stay looking good forever.

CERAMIC BOARD

SIZE (MM) APPROX.	SIZE (MM) APPROX.
300X450	600X1800
300X600	900X1200
450X600	1200X1200
450X900	1200X1500
600X600	1200X1800
600X900	1200X2400
600X1200	1200X3000
600X1500	1200X3600

MAGNETIC BOARD

SIZE (MM) APPROX.	SIZE (MM) APPROX.	SIZE (MM) APPROX.
300X450	600X1800	1200X1500
300X600	900X900	1200X1800
450X600	900X1200	1200X2400
450X900	900X1500	1200X3000
600X600	900X1800	1200X3600
600X900	900X2400	—
600X1200	900X3000	—
600X1500	1200X1200	—

NON-MAGNETIC BOARD

SIZE (MM) APPROX.	SIZE (MM) APPROX.	SIZE (MM) APPROX.
300X450	600X1800	1200X1800
300X600	900X900	1200X2400
450X600	900X1200	1200X3000
450X900	900X1500	1200X3600
600X600	900X1800	—
600X900	900X2400	—
600X1200	1200X1200	—
600X1500	1200X1500	—

CERAMIC BOARD

SIZE (MM) APPROX.	SIZE (MM) APPROX.
300X450	600X1800
300X600	900X1200
450X600	1200X1200
450X900	1200X1500
600X600	1200X1800
600X900	1200X2400
600X1200	1200X3000
600X1500	1200X3600

MAGNETIC BOARD

SIZE (MM) APPROX.	SIZE (MM) APPROX.	SIZE (MM) APPROX.
300X450	600X1800	1200X1500
300X600	900X900	1200X1800
450X600	900X1200	1200X2400
450X900	900X1500	1200X3000
600X600	900X1800	1200X3600
600X900	900X2400	—
600X1200	900X3000	—
600X1500	1200X1200	—

NON-MAGNETIC BOARD

SIZE (MM) APPROX.	SIZE (MM) APPROX.	SIZE (MM) APPROX.
300X450	600X1800	1200X1800
300X600	900X900	1200X2400
450X600	900X1200	1200X3000
450X900	900X1500	1200X3600
600X600	900X1800	—
600X900	900X2400	—
600X1200	1200X1200	—
600X1500	1200X1500	—



- ▶ Apart from the refreshing visual impact that they provide, the quality of the Glass Writing experience is Superb, Simple, Effective & Extraordinary.
- ▶ Dry wipe surface in a choice of colours, is a stylish back painted Writing Board that will suit any office, training room or boardroom.
- ▶ Clear, toughened safety glass with strong & sturdy satin anodised Stud fixings.
- ▶ This exciting and versatile glass alternative to the traditional white marker board can be used in countless settings, such as the office, boardroom, hospitals, doctors surgery, schools and colleges, even in the home now-a-days!
- ▶ The Glass Wipe Board will fit perfectly in any work environment or interior setting.
- ▶ Manufactured from 6.0mm & 8.0 mm safety glass that also features highly polished rounded edges and corners.
- ▶ **Note:** Glass Writing boards can be mounted in portrait or in landscape view. Professional installation may be required where board size dictates. Lead time for this product is around 5-7 working days.



Glass writing boards in different colours

SIZE (MM) APPROX.		
450X600	600X1800	1200X1200
600X900	900X1200	1200X1500
600X1200	900X1500	1200X1800
600X1500	900X1800	1200X2400



- ▶ Apart from the refreshing visual impact that they provide, the quality of the Glass Writing experience is Superb, Simple, Effective & Extraordinary.
- ▶ Dry wipe surface in a choice of colours, is a stylish back painted Writing Board that will suit any office, training room or boardroom.
- ▶ Clear, toughened safety glass with strong & sturdy satin anodised Stud fixings.
- ▶ This exciting and versatile glass alternative to the traditional white marker board can be used in countless settings, such as the office, boardroom, hospitals, doctors surgery, schools and colleges, even in the home now-a-days!
- ▶ The Glass Wipe Board will fit perfectly in any work environment or interior setting.
- ▶ Manufactured from 6.0 mm & 8.0mm safety glass that also features highly polished rounded edges and corners.
- ▶ **Note:** Glass Writing boards can be mounted in portrait or in landscape view. Professional installation may be required where board size dictates. Lead time for this product is around 5-7 working days.



SIZE (MM) APPROX.		
450X600	600X1800	1200X1200
600X900	900X1200	1200X1500
600X1200	900X1500	1200X1800
600X1500	900X1800	1200X2400

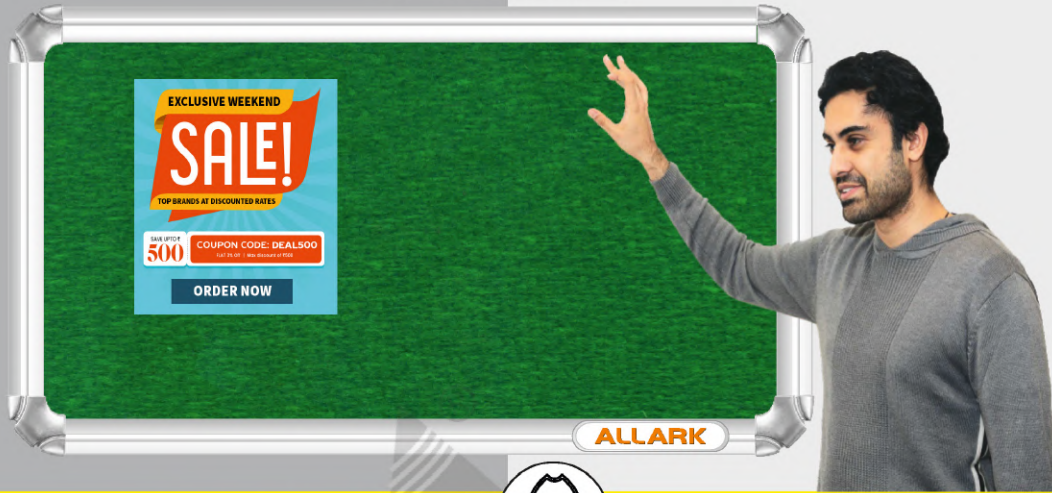

ALLARK

Felt :



Astel

- Well known as Soft Board/Pin-up Board/Bulletin Board used in Schools/Offices/Public Places for display of articles and notices with the help of Push Pins, Drawing Pins etc...
- Non Woven Felt Cloth used for the surface of the Felt Notice Board.
- Felt available in six different colours i.e. Beige/Blue/Green/Grey/Maroon & Red.
- Following The instructions provided, any persons can manage this task easily and safely install the board on the wall using spares supplied inside each board.



Umex-FT Umex-CR



Umex-FT Umex-CR

SIZE (MM) APPROX.	SIZE (MM) APPROX.	SIZE (MM) APPROX.
300X300	600X1200	900X2400
300X450	600X1500	1200X1200
300X600	600X1800	1200X1500
450X600	900X900	1200X1800
450X900	900X1200	1200X2400
600X600	900X1500	---
600X900	900X1800	---

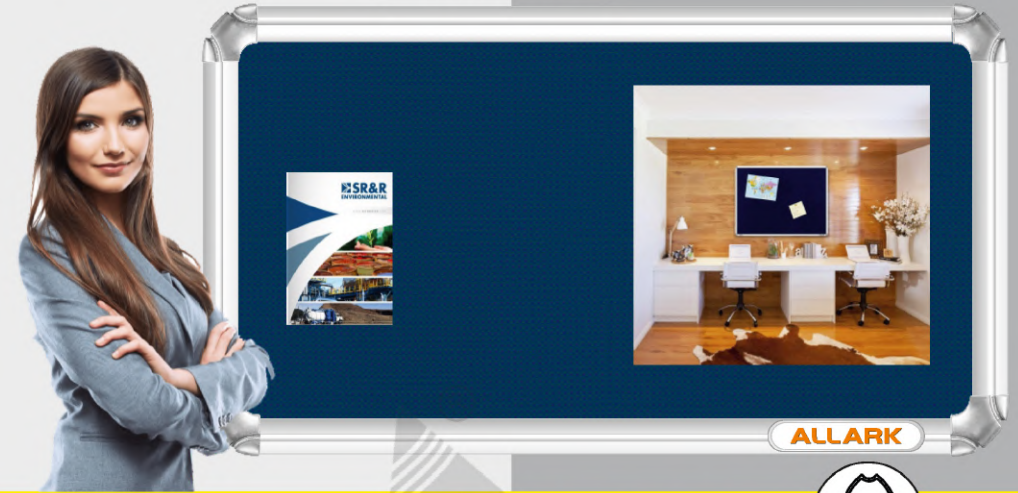

ALLARK

Fabrics :



Astel

- Well known as Soft Board/Pin-up Board/Bulletin Board used in Schools/Offices/Public Places for display of articles and notices with the help of Push Pins, Drawing Pins etc...
- Polyester Fabric cloth used for the surface of the Fabric Board
- Fabric available in different colours. Grey/Navy Blue/Light Blue/Red/Green/Maroon/Orange/Yellow
- Following The instructions provided, any persons can manage this task easily and safely install the board on the wall using spares supplied inside each board.



Umex-FT Umex-CR

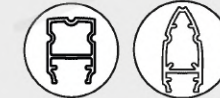

Umex-FT Umex-CR

SIZE (MM) APPROX.	SIZE (MM) APPROX.	SIZE (MM) APPROX.
300X300	600X1200	900X2400
300X450	600X1500	1200X1200
300X600	600X1800	1200X1500
450X600	900X900	1200X1800
450X900	900X1200	1200X2400
600X600	900X1500	---
600X900	900X1800	---

Umex-FT Series



Umex-FT



Cork

ALLARK



Eco Astel Series

Felt Pin Up Notice Board



Fabric Pin Up Notice Board



Cork Pin Up Notice Board

- Surface material Cork Sheet.
- Thickness of the Cork Sheet being 1 mm pasted on a good quality soft board.
- Used in Schools/Offices/Public Places for display of articles and notices with the help of Push Pins, Drawing Pins etc...
- Following The instructions provided, any persons can manage this task easily and safely install the board on the wall using spares supplied inside each board.

FELT PIN UP NOTICE BOARD

- Well known as Soft Board/Pin-up Board/Bulletin Board used in Schools/Offices/Public Places for display of articles and notices with the help of Push Pins, Drawing Pins etc...
- Non Woven Felt Cloth used for the surface of the Felt Notice Board.
- Felt available in six different colours i.e. Beige/Blue/Green/Grey/Maroon & Red.

FABRIC PIN UP NOTICE BOARD

- Well known as Soft Board/Pin-up Board/Bulletin Board used in Schools/Offices/Public Places for display of articles and notices with the help of Push Pins, Drawing Pins etc...
- Polyester Fabric cloth used for the surface of the Fabric Board
- Fabric available in different colours. Grey/Navy Blue/Light Blue/Red/Green/Maroon/Orange/Yellow

CORK PIN UP NOTICE BOARD

- Surface material Cork Sheet.
- Thickness of the Cork Sheet being 1 mm pasted on a good quality soft board.
- Used in Schools/Offices/Public Places for display of articles and notices with the help of Push Pins, Drawing Pins etc...



Astel Series

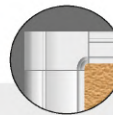

Umex-CR



Astel



Umex-CR



Eco Astel

SIZE (MM) APPROX.	SIZE (MM) APPROX.	SIZE (MM) APPROX.
300X450	600X1200	1200X1200
300X600	600X1800	1200X1500
450X600	900X900	1200X1800
450X900	900X1200	1200X2400
600X600	900X1500	---
600X900	900X1800	---

FELT PIN UP / FABRIC PIN UP NOTICE BOARD		
SIZE (MM) APPROX.	SIZE (MM) APPROX.	SIZE (MM) APPROX.
450X600	900X900	1200X1500
600X600	900X1200	1200X1800
600X900	900X1500	1200X2400
600X1200	900X1800	---
600X1800	1200X1200	---

CORK PIN UP NOTICE BOARD	
SIZE (MM) APPROX.	SIZE (MM) APPROX.
600X900	900X900
600X1200	900X1200
600X1800	---



Hanging Series

Felt Pin Up Notice Board

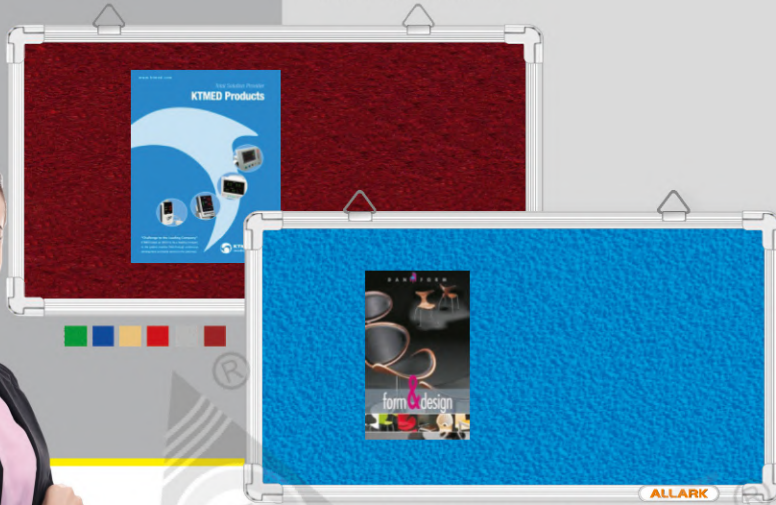

Fabric Pin Up Notice Board



- ▶ Well known as Soft Board/Pin-up Board/Bulletin Board used in Schools/Offices/Public Places for display of articles and notices with the help of Push Pins, Drawing Pins etc...
- ▶ Non Wooven Felt Cloth used for the surface of the Felt Notice Board.
- ▶ Felt available in six different colours i.e. Beige/Blue/Green/Grey/Maroon & Red.
- ▶ Polyester Fabric cloth used for the surface of the Fabric Board
- ▶ Fabric available in different colours. Grey/Navy Blue/Light Blue/Red/Green/Maroon/Orange/Yellow
- ▶ Following The instructions provided, any persons can manage this task easily and safely install the board on the wall using spares supplied inside each board.

SIZE (MM) APPROX.	SIZE (MM) APPROX.	SIZE (MM) APPROX.
300X300	600X1800	1200X2400
300X450	900X900	----
300X600	900X1200	----
450X600	900X1500	----
450X900	900X1800	----
600X600	1200X1200	----
600X900	1200X1500	----
600X1200	1200X1800	----



Hanging

Eco Hanging Series

Felt Pin Up Notice Board



FELT PIN UP NOTICE BOARD

- ▶ Well known as Soft Board/Pin-up Board/Bulletin Board used in Schools/Offices/Public Places for display of articles and notices with the help of Push Pins, Drawing Pins etc...
- ▶ Non Wooven Felt Cloth used for the surface of the Felt Notice Board.
- ▶ Felt available in six different colours i.e. Beige/Blue/Green/Grey/Maroon & Red.

FABRIC PIN UP NOTICE BOARD

- ▶ Well known as Soft Board/Pin-up Board/Bulletin Board used in Schools/Offices/Public Places for display of articles and notices with the help of Push Pins, Drawing Pins etc...
- ▶ Polyester Fabric cloth used for the surface of the Fabric Board
- ▶ Fabric available in different colours. Grey/Navy Blue/Light Blue/Red/Green/Maroon/Orange/Yellow

CORK PIN UP NOTICE BOARD

- ▶ Surface material Cork Sheet.
- ▶ Thickness of the Cork Sheet being 1 mm pasted on a good quality soft board.
- ▶ Used in Schools/Offices/Public Places for display of articles and notices with the help of Push Pins, Drawing Pins etc...

FELT PIN UP / FABRIC PIN UP NOTICE BOARD

SIZE (MM) APPROX.	SIZE (MM) APPROX.	SIZE (MM) APPROX.
450X600	900X900	1200X1500
600X600	900X1200	1200X1800
600X900	900X1500	1200X2400
600X1200	900X1800	----
600X1800	1200X1200	----

CORK PIN UP NOTICE BOARD

SIZE (MM) APPROX.	SIZE (MM) APPROX.
600X900	900X900
600X1200	900X1200
600X1800	----



Hanging

Fabric Pin Up Notice Board

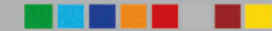

Cork Pin Up Notice Board



Umex- CR Series



Felt Pin Up Notice Board



Fabric Pin Up Notice Board

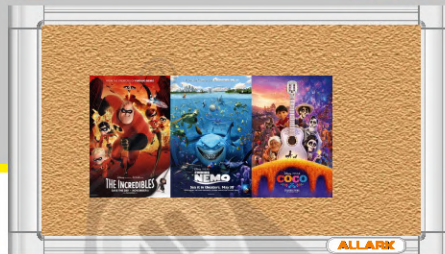

Cork Pin Up Notice Board

Umex- FT Series



Felt Pin Up Notice Board



Fabric Pin Up Notice Board



Cork Pin Up Notice Board

FELT PIN UP NOTICE BOARD

- ▶ Well known as Soft Board/Pin-up Board/Bulletin Board used in Schools/Offices/Public Places for display of articles and notices with the help of Push Pins, Drawing Pins etc...
- ▶ Non Woven Felt Cloth used for the surface of the Felt Notice Board.
- ▶ Felt available in six different colours i.e. Beige/Blue/Green/Grey/Maroon & Red.

FABRIC PIN UP NOTICE BOARD

- ▶ Well known as Soft Board/Pin-up Board/Bulletin Board used in Schools/Offices/Public Places for display of articles and notices with the help of Push Pins, Drawing Pins etc...
- ▶ Polyester Fabric cloth used for the surface of the Fabric Board
- ▶ Fabric available in different colours. Grey/Navy Blue/Light Blue/Red/Green/Maroon/Orange/Yellow

CORK PIN UP NOTICE BOARD

- ▶ Surface material Cork Sheet.
- ▶ Thickness of the Cork Sheet being 1 mm pasted on a good quality soft board.
- ▶ Used In Schools/Offices/Public Places for display of articles and notices with the help of Push Pins, Drawing Pins etc...

FELT PIN UP NOTICE BOARD

- ▶ Well known as Soft Board/Pin-up Board/Bulletin Board used in Schools/Offices/Public Places for display of articles and notices with the help of Push Pins, Drawing Pins etc...
- ▶ Non Woven Felt Cloth used for the surface of the Felt Notice Board.
- ▶ Felt available in six different colours i.e. Beige/Blue/Green/Grey/Maroon & Red.

FABRIC PIN UP NOTICE BOARD

- ▶ Well known as Soft Board/Pin-up Board/Bulletin Board used in Schools/Offices/Public Places for display of articles and notices with the help of Push Pins, Drawing Pins etc...
- ▶ Polyester Fabric cloth used for the surface of the Fabric Board
- ▶ Fabric available in different colours. Grey/Navy Blue/Light Blue/Red/Green/Maroon/Orange/Yellow

CORK PIN UP NOTICE BOARD

- ▶ Surface material Cork Sheet.
- ▶ Thickness of the Cork Sheet being 1 mm pasted on a good quality soft board.
- ▶ Used in Schools/Offices/Public Places for display of articles and notices with the help of Push Pins, Drawing Pins etc...

FELT PIN UP / FABRIC PIN UP NOTICE BOARD

SIZE (MM) APPROX.	SIZE (MM) APPROX.	SIZE (MM) APPROX.
450X600	900X900	1200X1500
600X600	900X1200	1200X1800
600X900	900X1500	1200X2400
600X1200	900X1800	—
600X1800	1200X1200	—

CORK PIN UP NOTICE BOARD

SIZE (MM) APPROX.	SIZE (MM) APPROX.
600X900	900X900
600X1200	900X1200
600X1800	—

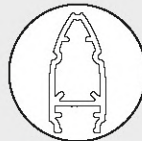

Umex-CR



Umex-FT

SIZE (MM) APPROX.	SIZE (MM) APPROX.	SIZE (MM) APPROX.
300X300	600X1200	900X2400
300X450	600X1500	1200X1200
300X600	600X1800	1200X1500
450X600	900X900	1200X1800
450X900	900X1200	1200X2400
600X600	900X1500	—
600X900	900X1800	—



Felt + Ceramic Combination Board



Cork + Non Magnetic Combination Board



Fabric + Magnetic Combination Board



Felt + Ceramic Combination Board



COMBINATION BOARD

- Dual Purpose Notice Board.
- Half Ceramic/Magnetic/Non Magnetic can be used for writing with markers, and Half Felt/Fabric/Cork for Pin Up.
- Following the instructions provided, any person can manage this task easily and safely install the Board on the wall using spares supplied inside each board.

SIZE (MM) APPROX.	SIZE (MM) APPROX.	SIZE (MM) APPROX.
450X600	900X900	1200X1500
450X900	900X1200	1200X1800
600X900	900X1500	1200X2400
600X1200	900X1800	—
600X1800	1200X1200	—

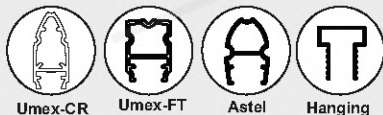

Umex-CR Umex-FT Astel Hanging



Front Side
White Marker &
Back Side Green Chalk
Board

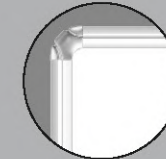

Front Side
White Marker
Board

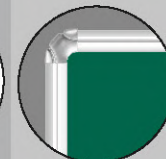

Back Side
Green Chalk
Board

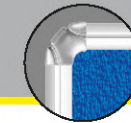

Front Side
Felt / Fabric
Pin Up Notice Board



Back Side
White Marker
Board

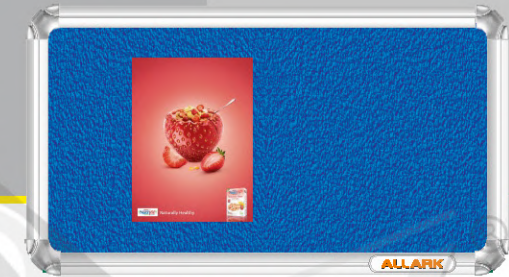

Fabric : Felt :

Double Sided Board

- Two-sided boards with surfaces in White Marker + Green Chalk + Display, which offer the possibility to Write & Pin Up on any sides, exploiting the space available at best. A great choice for schools, offices, businesses, hospitals or any area where lectures or lessons are given.
- This both Sided board after mounting on a Revolving Stand, can rotate by 360° and be locked in the desired position with a help of the knob affixed on Stand. Stable and compact structure of the stand can be moved on Castor wheels.
- Possibility to match useful combinations, Front/Back for Writing (Non Magnetic, Magnetic & Ceramic) Like, White Marker + White Marker or White Marker + Green Chalk or Green Chalk + Green Chalk.
- Can match possible combinations, Front/Back for Writing & Display (Non Magnetic, Magnetic & Ceramic) Like White Marker + Felt Pin Up Notice Board or White Marker + Fabric Pin Up Notice Board. One Side can be Used for Writing & other side for Display.
- Can match possible combinations, Front/Back for Display Like Felt + Felt or Fabric + Fabric. Both the Sides can be used for displaying Notices in Passages, Lobby, Receptions, Conference areas or Exhibitions Halls and many more places.
- These both Sided Boards are suitable for mounting on Revolving Stands, 3 Leg Stands, & 4 Leg Stands, 'A' Type Display Stands only & 'Y' Type Stands with a set of Hingis.
- These Boards are not provided with any Wall mounting arrangements.
- Also available In Economy Astel Series

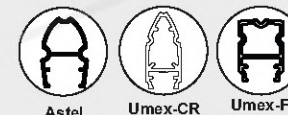

Astel Umex-CR Umex-FT

SIZE (MM) APPROX.			
450X600	900X1200	1200X1500	1200X2400
600X900	900X1500	1200X1800	—



Hanging Series

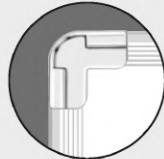

Front Side White Marker Board



Back Side Green Chalk Board



Front Side Felt / Fabric Pin Up Notice Board



Back Side White Marker Board



Double Sided Board Writing / Notice / Display Board

Fabric : Felt :

Double Sided Boards

- ▶ Two-sided boards with surfaces in White Marker + Green Chalk + Display, which offer the possibility to Write & Pin Up on any sides, exploiting the space available at best. A great choice for schools, offices, any area where lectures or lessons are given.
- ▶ Possibility to match useful combinations, Front/Back for Writing (Non Magnetic, Magnetic & Ceramic) Like, White Marker + White Marker or White Marker + Green Chalk or Green Chalk + Green Chalk.
- ▶ Can match possible combinations, Front/Back for Writing & Display (Non Magnetic, Magnetic & Ceramic) Like White Marker + Felt Pin Up Notice Board or White Marker + Fabric Pin Up Notice Board. One Side can be Used for Writing & other side for Display.
- ▶ Can match possible combinations, Front/Back for Display Like Felt + Felt or Fabric + Fabric. Both the Sides can be used for displaying Notices in Passages, Lobby, Receptions, Conference areas or Exhibitions Halls and many more places.
- ▶ These Boards can be used on both the sides with a unique set of hanging hooks provided on the frame, wherein you can easily remove or Hang/mount the board for utilizing any writing surface either ways.
- ▶ Following the instructions provided, any persons can manage this task easily and safely install the board on the wall using spares supplied inside each board.
- ▶ These both Sided Boards can be easily mounted on 3 Leg Stands, 4 Leg Stands, 'A' Type Display Stands & on 'Y' Type Stands with a set of Hings.
- ▶ Also available in Economy Hanging Series



Hanging

SIZE (MM) APPROX.				
300X450	600X900	900X1500	1200X1500	1200X2400
450X600	900X1200	900X1800	1200X1800	---

Astel Series



Grooved Boards Velvet :



Door Covered Grooved Display Boards

Velvet :

SIZES OF GOLDEN LETTERS & FIGURES

LETTERS SET OF 112		FIGURES SET OF 100	
AEIO	5 Each	20 Pcs.	14 Each
CNRST	4 Each	20 Pcs.	10 Each
BDFGHK	3 Each	18 Pcs.	8 Each
LMPUWY	3 Each	18 Pcs.	8 Each
JQV	2 Each	06 Pcs.	8 Each
XZ	1 Each	02 Pcs.	2 Each
.	-	10 Pcs.	8 Each
,	-	04 Pcs.	10 Pcs.
-	-	05 Pcs.	24 Pcs.
()	-	02 Pcs.	8 Each
& % /	-	04 Pcs.	24 Pcs.
Total		112 Pcs.	100Pcs.

SIZE OF LETTERS	SIZE OF FIGURES
24mm	24mm
36mm	36mm

GROOVE BOARD

Very popularly known as Menu Board/Welcome/Display Board. Used in Offices/Hotels/Auditorium & Public Places for display information. Groove Board Velvet Colours available Red, Maroon & Black. Golden Letters & Figures are available in 24mm/36mm in English. Following the instructions provided, any person can manage this task easily and safely install the board on the wall using spares supplied inside each board.

DOOR COVERED GROOVE BOARD

Front Door Covered with golden aluminium framed acrylic sheet with lock and keys attachment.

GOLDEN STAND

Golden Stand for Groove Boards strong iron casted golden base. Height of the Golden Pipe 6ft.



Groove Board with single pole & WheelStand



Astel

SIZE (MM) APPROX. GROOVE BOARDS				SIZE (MM) APPROX. DOOR COVERED GROOVE NOTICE BOARDS	
300X450	600X600	600X1200/P	900X1200/P	450X600	900X900
450X600/P	600X900/P	1200X600/L	1200X900/L	600X900	900X1200
600X450/L	900X600/L	900X900	1200X1200	600X1200	---



Regular / Astel / Hanging Series

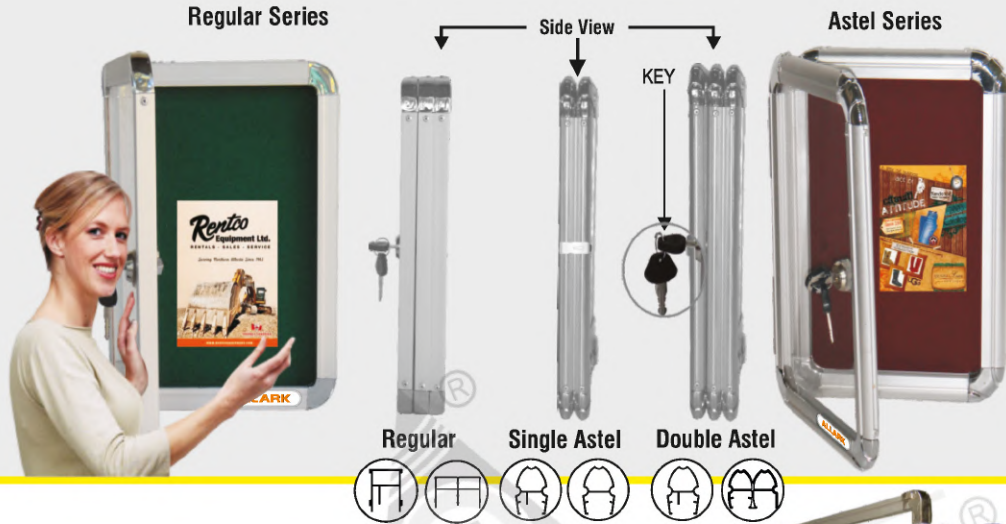

Regular Series

Side View

Astel Series



Front Door Covered with aluminium framed acrylic sheet which can be locked with a pair of keys provided with each board. The Board is backed with a soft board. Accepts Push Pins, Drawing Pins etc....



SIZE (MM) APPROX. REGULAR & ASTEL SERIES

450X600	900X1200	1200X1800
600X900	900X1500	1200X2400
600X1200	900X1800	---
900X900	1200X1500	---

SIZE (MM) APPROX. HANGING SERIES

450X600	900X1200	1200X1800
600X900	900X1500	---
600X1200	900X1800	---
900X900	1200X1500	---

Big Regular Series

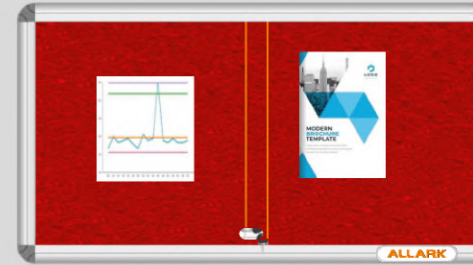

Sliding Glass Door Cover Boards
Felt / Fabric / Magnetic / Key Board

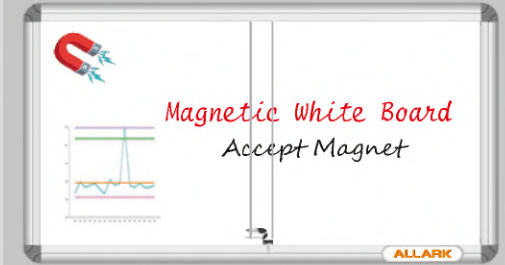

Sliding Glass Door Cover Boards
Magnetic Writing Board

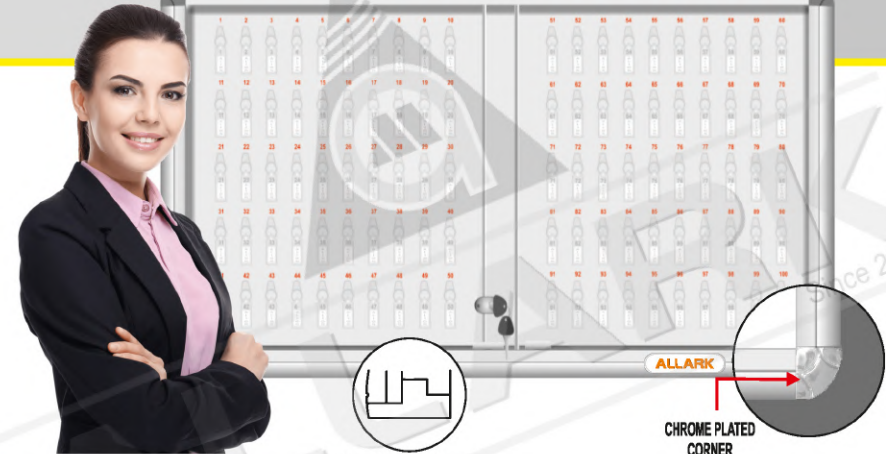

Big Regular Frame

CHROME PLATED CORNER ALSO AVAILABLE

SLIDING GLASS DOOR COVER
FELT/FABRIC PIN UP NOTICE BOARD

- ▶ Surface Material Available : Felt/Fabric/Cork
- ▶ Easy to pin up Notices, Flyers, Messages etc.

SLIDING GLASS DOOR COVER
MAGNETIC WRITING BOARD

- ▶ Surface Material Resin Coated Magnetic Writing Board
- ▶ Magnetic Push Pins, Magnetic Buttons can be used to put notices, flyers, Messages etc.

SLIDING GLASS DOOR COVER
KEY HOLDING BOARD

- ▶ Numbers printed on Steel Plate & Key Chain for Identification.

COMMON SPECIFICATION

- ▶ Sliding Glass moves smoothly on bearings.
- ▶ Lock provided on the sliding glass to keep Keys safe.
- ▶ Two keys provided with lock for safety.
- ▶ Sturdy Aluminium Frame 30mmX50mm
- ▶ MS Brackets provided at the back of the board, for installation on the wall.

- ▶ Available Capacity of holding Keys : 50 Keys & 100 Keys
- ▶ Size : 50 Keys : 6300mmX620mm
100 Keys : 630mmX1020mm



Regular / Double Astel Series

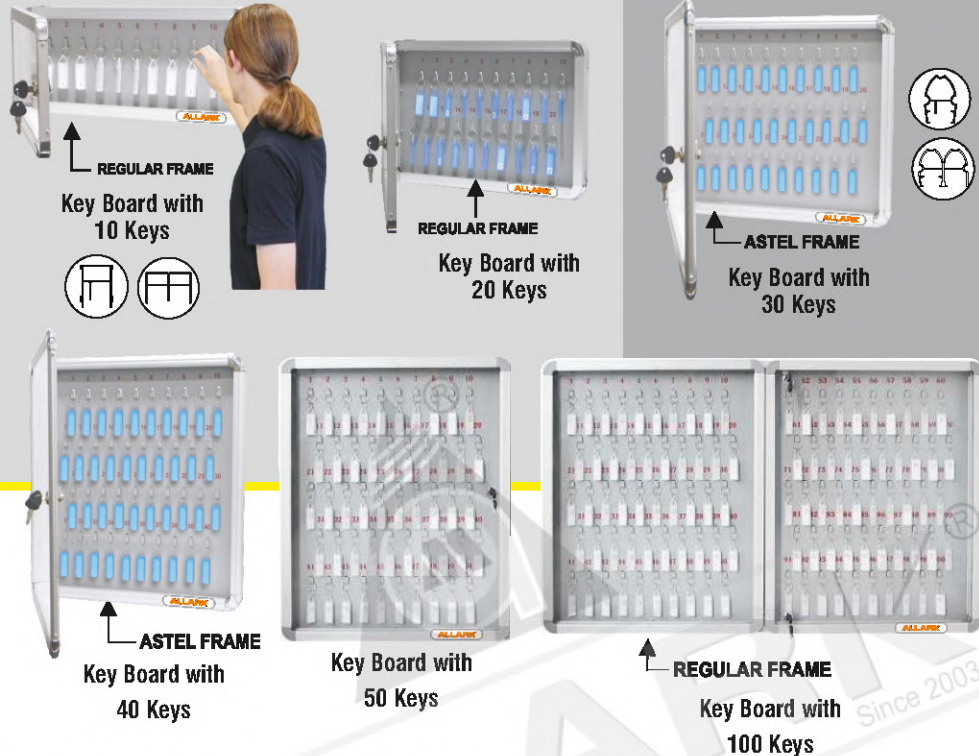

- ▶ Convenient way for storing keys with lock.
- ▶ Door cover with locking method.
- ▶ Sizes for storage : 10,20, 30, 40, 50 & 100 Keys.
- ▶ Paper slip in the Key Chain itself for writing information.

DESCRIPTION	SIZE (MM) APPROX.
Board for 10 Keys	195X500
Board for 20 Keys	304X500
Board for 30 Keys	405X500
Board for 40 Keys	515X500
Board for 50 Keys	610X500
Board for 100 Keys	990X620



**PORTABLE FOLDABLE
LAPTOP/NOTE BOOK TABLE**

SPECIALLY
DESIGNED FOR
WORK FROM
HOME PURPOSES



- FEATURES**
- ▶ Portable Foldable Laptop/Note Book Table.
 - ▶ Can be carried anywhere, flexible and comfortable.
 - ▶ Adjustable height and angle with lock design feature.
 - ▶ Can be used for Laptop, Reading and Eating etc.
 - ▶ Specially designed for work from Home Purpose.
 - ▶ Table legs are made wide enough, so to avoid shakiness and can easily fit over your folded legs, this makes the table sturdy and long lasting.
 - ▶ It has enough board space for Laptop and Mouse and can surely add more comfort to your studying and reading sessions.

SIZES & COLOURS

12" X 24" (30CMS X 60CMS)
18" X 24" (45CMS X 60CMS)

WOOD FINISH

BLACK FINISH





MULTI PURPOSE & FOLDING METAL STUDY TABLE

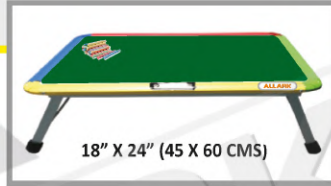
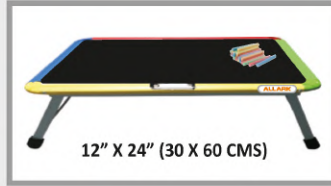
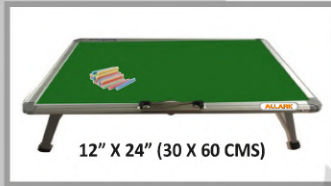

- ▶ Strong & Sturdy Design, Can be used as : Children Study Table, Drawing Purpose, Art N Craft, Board Games, Reading & Writing, Multipurpose.
- ▶ Great for Students who needs to study & have less space.
- ▶ Adjust height & angle with lock design feature.
- ▶ Pad Clip provided to hold Papers, Drawing Books etc..
- ▶ Can be easily folded & carried anywhere, flexible & comfortable.
- ▶ Anti skid rubber bush provided for firm grip on any smooth surfaces.
- ▶ Available in different Sizes : 12" x 18"(30 X 45 cms), 12" x 24"(30 X 60 cms) & 18" x 24"(45 X 60 cms.)
- ▶ Surfaces available in Black & Green for writing with chalks.

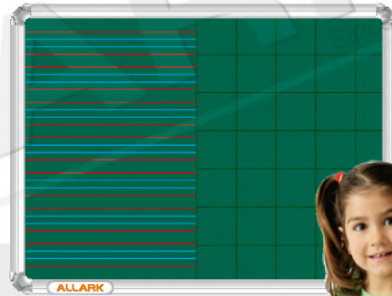

Kidz Board
4 lined & Graph Board

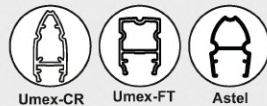

FOUR LINED & GRAPH BOARD

- ▶ Especially designed for Kg & Playgroup section.
- ▶ 4 lines gives accuracy in cursive writing.
- ▶ Graph can be used for accurate drawing & to write numericals.
- ▶ Available in Non Magnetic/Magnetic/Ceramic Green Chalk Surface only.

SIZES AVAILABLE (APPROX MM.)

FOUR LINED & GRAPH BOARD

900X1200 mm.	1200X1800 mm.
1200X2400 mm.	1200X3000 mm.



Lobby Information Board

- ▶ Very popularly known as MenuBoard/Welcome/Display Board
- ▶ Used in Offices/Hotels/Auditorium & Public Places for display information.
- ▶ Door Covered Groove Board Velvet Colours Available - Red & Maroon.
- ▶ Golden Letters & Figures are available in 24mm/36mm in English.
- ▶ Golden Stand Made of MS Steel Angular Cut with Golden Powder Coating.
- ▶ Black Stand Made of MS Steel Angular Cut with Black Powder Coating.

SIZE AVAILABLE
600x900mm (P)

VELVET COLOURS COLOURS 

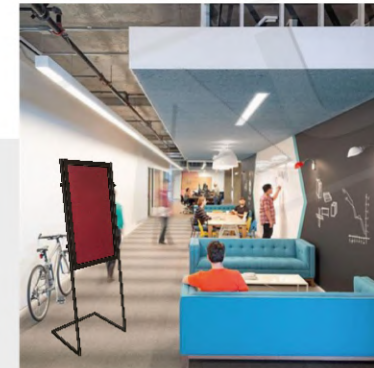



First Aid Box

- ▶ Made of Virgin Plastic for Anti-Rust Proofing for Long Lasting.
- ▶ High Quality Amazing Aesthetics & Perfect for Daily Life Use.
- ▶ Front Transparent PS Door with Multi Compartment 3-Shelf for Better Organize of Medicines with Security Lock on Door for Safety.
- ▶ Ideal for Home, Office, School, Petrol Pump, Factory, Shops
- ▶ Dimensions : (H) 30 X (W) 25 X (D) 10 Cms.
- ▶ Easy Wall Mount Installation with Free Fittings.



Suggestion Box

- ▶ Multi-purpose Suggestion Box.
- ▶ Made of Virgin Plastic for Anti-Rust Proofing for Long Lasting.
- ▶ Can be used for Feedback, Donations, Business cards and contest entries as well.
- ▶ Front Transparent PS Door with Security Lock on Door for Safety
- ▶ Useful for Colleges, Institute, Offices, Schools etc.,
- ▶ Dimensions : (H) 30 X (W) 25 X (D) 10 Cms.
- ▶ **Easy Wall Mount Installation with Free Fittings.**



Letter Box

- ▶ Made of ABS Plastic for Long Lasting.
- ▶ No corrosion, No Peeling of Coating.
- ▶ Front Door with Coloured PS Door with Security Lock on Door for Safety.
- ▶ Size Enough to Contain A4 Sized Letters.
- ▶ 100% Weather Proof and Best Suited for Outdoor Use.
- ▶ Ideal for Societies, Office, School, Petrol Pump, Factory, Shops.
- ▶ Dimensions : (H) 28 X (W) 23 X (D) 8 Cms.
- ▶ Easy Wall Mount Installation with Free Fittings.

Astel Series



Astel Exhibition Display System

- ▶ Easy to assemble modular system especially for exhibitions and receptions.
- ▶ Heavy duty lobby stands keep the system stable.
- ▶ Dry wipe magnetic boards at top to display messages. Multi position fitting enables placement of panels at different angles.
- ▶ The system can be custom made to suit your requirement.



Art No.ALEDS1
2 Nos. Mag. Boards .75x3
2 Nos. Felt/Fabric Boards 2x3
2 Nos. Felt/Fabric Boards 3x3
3 Nos. Lobby Stands
H: 5.25, W: 6.25



Art No.ALEDS2
3 Nos. Mag. Boards .75x3
3 Nos. Felt/Fabric Boards 2x3
3 Nos. Felt/Fabric Boards 3x3
4 Nos. Lobby Stands
H: 5.25, W: 9.35

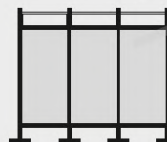

Art No.ALEDS3
3 Nos. Mag. Boards .75x3
3 Nos. Felt/Fabric Boards 5x3
4 Nos. Lobby Stands
H: 5.25, W: 9.35

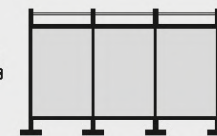

Art No.ALEDS4
3 Nos. Mag. Boards .75x4
3 Nos. Felt/Fabric Boards 5x4
4 Nos. Lobby Stands
H: 5.25, W: 12.30

Unlimited Combinations

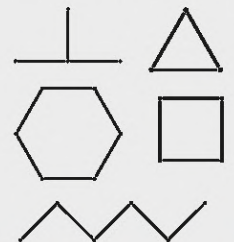



Astel / Hanging Series

Dim Kit



- ▶ Both Sided Board.
- ▶ Can easy assembled on occasion.
- ▶ Strong hinges provided for proper locking of the board on the stand.
- ▶ Display in minutes. Available in non woven felt & polyester fabric.
- ▶ Felt available in six different colours i.e. Beige/Blue/Green/Grey/Maroon & Red.
- ▶ Fabric available in different colours.
Grey/Navy Blue/Light Blue/Red/Green/Maroon/Orange/Yellow
- ▶ Sizes available in 600X900mm & 900X1200mm.



Planner Board

Weekly / Monthly & Yearly Planner

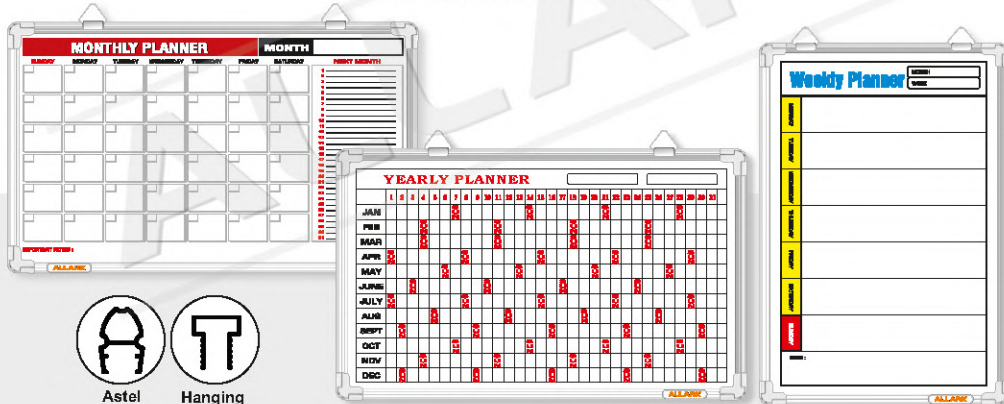

Flip chart Board with Holder & Three Leg Stabd Stands

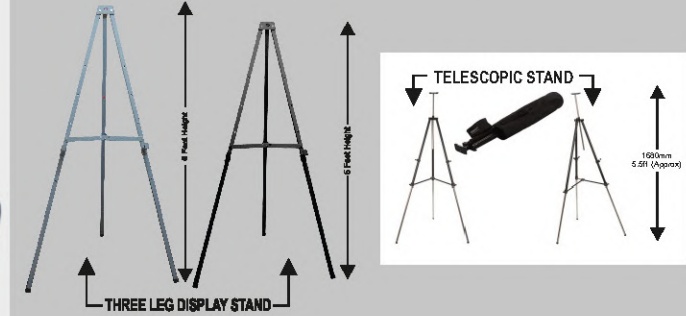

THREE LEG STAND

- ▶ Three leg display stand strong and sturdy.
- ▶ Non skid rubber pads provided for the board to rest.
- ▶ Holes provided for the board adjustments.
- ▶ 5 ft. Height available for board size upto 600 X 900 mm.
- ▶ 6 ft. Height available for board size upto 900 X 1200 mm.
- ▶ Available in 1" X 1" & 3/4" X 3/4" in M.S. Pipe.
- ▶ Order board separately.
- ▶ Colour available : Powder Coated Grey & Black

Flip chart Board Holder

- ▶ The Collapsible Easel Stand.
- ▶ Floor standing with an overall extended height of 1680 mm or on desktable top.
- ▶ Sturdy Steel Tripod stand with telescopic adjustable legs.
- ▶ Clamping of board from top to avoid vibration.
- ▶ Easy to stock and re-setup.
- ▶ Bag provided for easy storage.

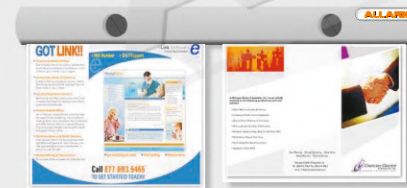

Wooden Stand for Wooden Frame Board 5 Feet

FLIP CHART WRITING BOARD

- ▶ Especially Designed for meeting rooms/ Conference Rooms & for Presentations Halls.
- ▶ Board available in Non-Magnetic/Magnetic & Ceramic Surfaces.
- ▶ Standard Board Size Is 700 x 1000 mm.

FLIP CHART HOLDER

- ▶ Very economical paper holding system.
- ▶ Made of M.S. Steel powder coated.
- ▶ Size of the holder Is 600 mm.

FLIP CHART PAPER

- ▶ Used for mounting on flip chart holders.
- ▶ Thickness of the paper 75gms.
- ▶ Size of the paper is 585 X 900 mm.

WOODEN STAND

- ▶ Used to Mount Wooden Frame Boards.
- ▶ Available sizes 5 ft. & 6 ft
- ▶ Order board separately.

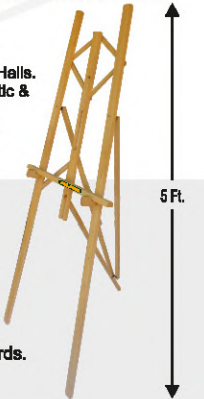

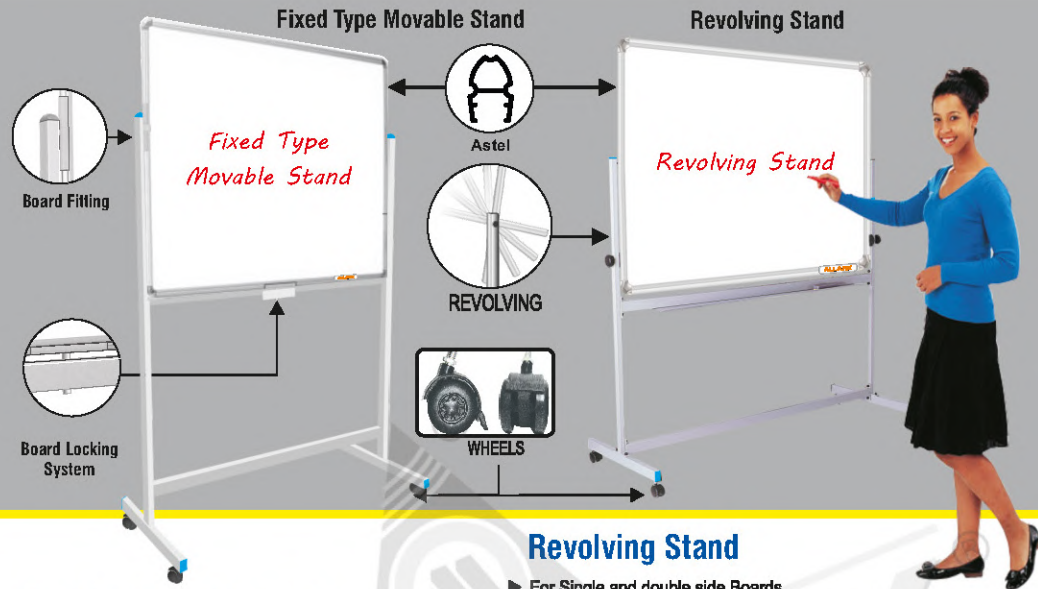

Fixed Type Movable Stand

- ▶ For fixed single & double side boards.
- ▶ Heavy duty castors provided to move the stand.
- ▶ Can be easily assembled.
- ▶ Suitable for Board Sizes :- 600x900mm, 900x1200mm, 900x1500mm, 900x1800mm 1200x1500mm, 1200x1800mm, 1200x2400mm, 1200x3000mm & 1200x3600mm and can be fabricated as per customer's design's.
- ▶ Order Board separately.

Revolving Stand

- ▶ For Single and double side Boards.
- ▶ Board can be locked with a sturdy locking attachments.
- ▶ Heavy duty castors provided to move the stand.
- ▶ Can be easily assembled.
- ▶ Suitable for Board Sizes :- 600x900mm, 900x1200mm, 900x1500mm, 900x1800mm 1200x1500mm, 1200x1800mm, 1200x2400mm, and can be fabricated as per customer's design's.
- ▶ Order Board separately.



Four Legged Display Stand

- ▶ Four legged display stand for bigger sized boards strong and sturdy.
- ▶ Can be easily assembled.
- ▶ Suitable for board size above 900X1200mm. & upto 1200X2400mm.
- ▶ Order board separately.

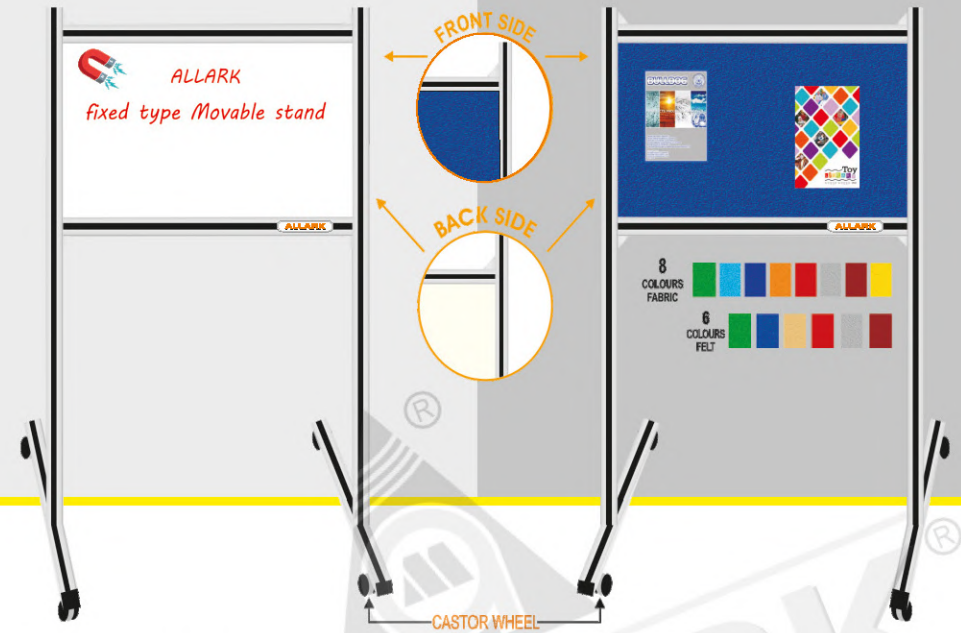

- ▶ Made from Heavy Duty Aluminium Profile.
- ▶ For fixed single & double side boards.
- ▶ Heavy Duty Castors provided to move the Stand.
- ▶ Can be easily assembled.

Can install it both side :

- ▶ Non Magnetic + Non Magnetic, Non Magnetic + Felt / Fabric
- ▶ Magnetic + Magnetic, Magnetic + Felt / Fabric
- ▶ Ceramic + Ceramic, Ceramic + Felt / Fabric
- ▶ Felt / Fabric + Felt / Fabric

All Fitting accessories provided with the stand.

SIZE (MM) APPROX.	SIZE (MM) APPROX.	SIZE (MM) APPROX.
600X900	900X1500	1200X1800
600X1200	900X1800	1200X2400
900X900	1200X1200	—
900X1200	1200X1500	—





PEN TRAY

- Ideal to keep Marker Pens & Chalks
- Colours available Grey & Chrome Plated



CHROME PLATED



GREY

Acrylic Writing Desk



Suggestion Box



- ▶ Holds comment cards, business cards etc.
- ▶ Made of clear acrylic.
- ▶ Insertion slot on top with sliding opening from back side.



NON MAGNETIC
CHALK BOARD DUSTER

NON MAGNETIC CHALK BOARD DUSTER

- ▶ Suitable for Green & Black Chalk Boards.
- ▶ Wipes Smoothly and Cleanly with the help of good quality Felt Cloth.
- ▶ Manufactured with best quality of Plastic & Felt.
- ▶ The size of the Duster is handy and can be kept easily in the Pen Tray attached to the board.



NON MAGNETIC
MARKER BOARD DUSTER

NON MAGNETIC MARKER BOARD DUSTER

- ▶ Suitable for Non-Magnetic White Marker Boards.
- ▶ Wipes Smoothly and Cleanly with the help of good quality Felt Cloth.
- ▶ Manufactured with best quality of Plastic & Felt.
- ▶ The size of the Duster is handy and can be kept easily in the Pen Tray attached to the board.

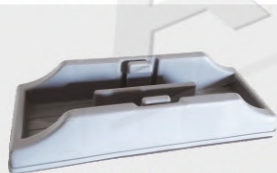

MAGNETIC DUSTER

MAGNETIC BOARD DUSTER

- ▶ Suitable for Magnetic White Marker Boards & Ceramic White Boards.
 - ▶ The Duster having magnetic property to hold them to remain fixed on the board.
 - ▶ Wipes Smoothly and Cleanly with the help of good quality Felt Cloth.
 - ▶ Manufactured with best quality of Plastic & Felt.
- The size of the Duster is handy and can be kept easily in the Pen Tray attached to the board.

- ▶ Convenient to use on table.
- ▶ Can be adjust in suitable angle.
- ▶ Can hold paper from the top.

Menu Holder



- Displays Menu on table.

SUGGESTION BOX SIZE (MM) APPROX.	ACRYLIC WRITING DESK SIZE (MM) APPROX.	MENU HOLDER SIZE (MM) APPROX.
200 X 200 X 300 150 X 150 X 250	580 X 400	125 X 180



Business Card Holder

- Convenient to keep business cards in one place.
- It can hold minimum 100 cards easily.



Wall Information Holder
Available in Portrait. & Landscape



Art No.	Sizes
A4 H-WIIP	210 X 297
A4 H-WIL	297 X 210
A5 H-WIIP	148 X 210
A5 H-WIL	210 X 148
A6 H-WIIP	105 X 148
A6 H-WIL	148 X 105

PORTRAIT

WALL INFORMATION HOLDER

- ▶ It can fix easily on wall, door etc. With the help of two predrilled holes.
- ▶ Made from clear acrylic.
- ▶ Information can be easily insert from top of the holder.

LANDSCAPE



Size
110W X 197H X 80 D. mm



Size
235W X 275H x 80 D. mm

Litreture Holder

- ▶ Holds literatures for distribution.
- ▶ Predrilled holes for fitting on walls.
- ▶ Made from clear acrylic sheet.

Wall Literature Holder

Available Size : A6, A5, A4, A3,
600X300mm & 900X1200mm
Can be customised also.

WALL MOUNTING STUD

- ▶ Brass Nickle plated screws & nuts for fixing on the wall.
- ▶ Opens from front for paper insertion.

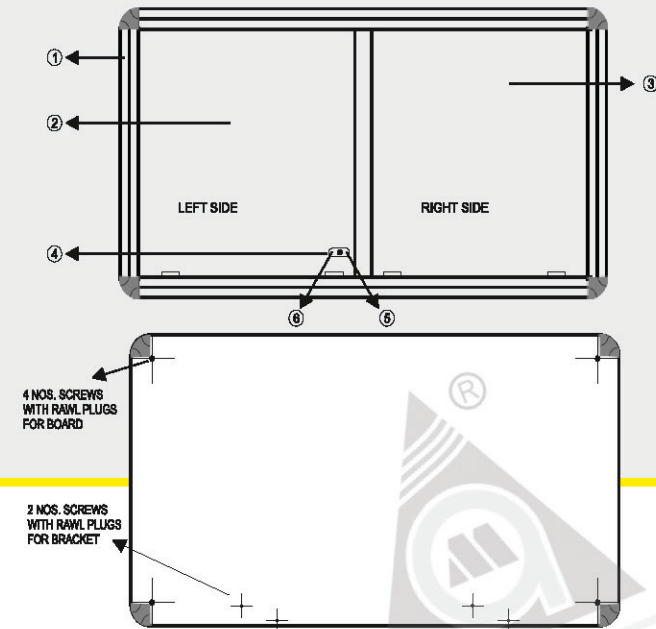

PART LIST		
BR. NO.	DESCRIPTION	QTY.
1	BOARD	1 NO.
2	LEFT GLASS FRONT	1 NO.
3	RIGHT GLASS FRONT	1 NO.
4	PUSH LOCK WITH KEY	1 SET
5	LOCK PLATE	1 NO.
6	SCREWS	2 NOS.
7	ALLEN KEY	1 NO.
8	SCREW & RAWL PLUG FOR BOARD	4 SET
9	WALL BRACKET	2 NOS.
10	SCREW & RAWL PLUG FOR BRACKET	4 SET

4 NOS. SCREWS WITH RAWL PLUGS FOR BOARD

2 NOS. SCREWS WITH RAWL PLUGS FOR BRACKET

Sliding Glass Board consist of the following Parts/Components.

1. Board in assembled condition. (Without glass and lock)
2. Left Glass (front) with hole for lock and screws with two glass runners.
3. Right Glass (back) with two glass runners.
4. Push Lock with key.
5. Lock Plate
6. Two numbers screws to fix lock plate with locks.
7. Allen keys.
8. Fixing Screws and Rawl Plugs.
9. Two numbers "L" Type wall mounting brackets.

Assembly Procedure.

Open carton and take out all the items as listed above.

Steps of Assembly

- STEP 1:** First fix the board without glass on the wall with four screws and rawl plugs. Take left glass and assemble lock and lock plate by pushing lock from back side of the glass. Place lock plate on projected portion of the lock from front. Put two screws from front and fasten it with Allen Keys
- STEP 2:** HOLD RIGHT glass in both the hands and place it on the back channel top side and then on bottom side. Glass size is kept in such a way that it can be easily placed in the back channel.
- STEP 3:** HOLD LEFT glass in both the hands and first place it in front channel top side and then on bottom side.
- STEP 4:** MARK the bottom line of the board and fix the two ("L" Bracket) support so that board can easily be mounted on the "L" Brackets & then fix the screen provided on the bottom frame.
- STEP 5:** Place board on wall after screws and brackets are fixed.



LINE DIAGRAM FOR MOUNTING OF THE BOARD ON THE WALL

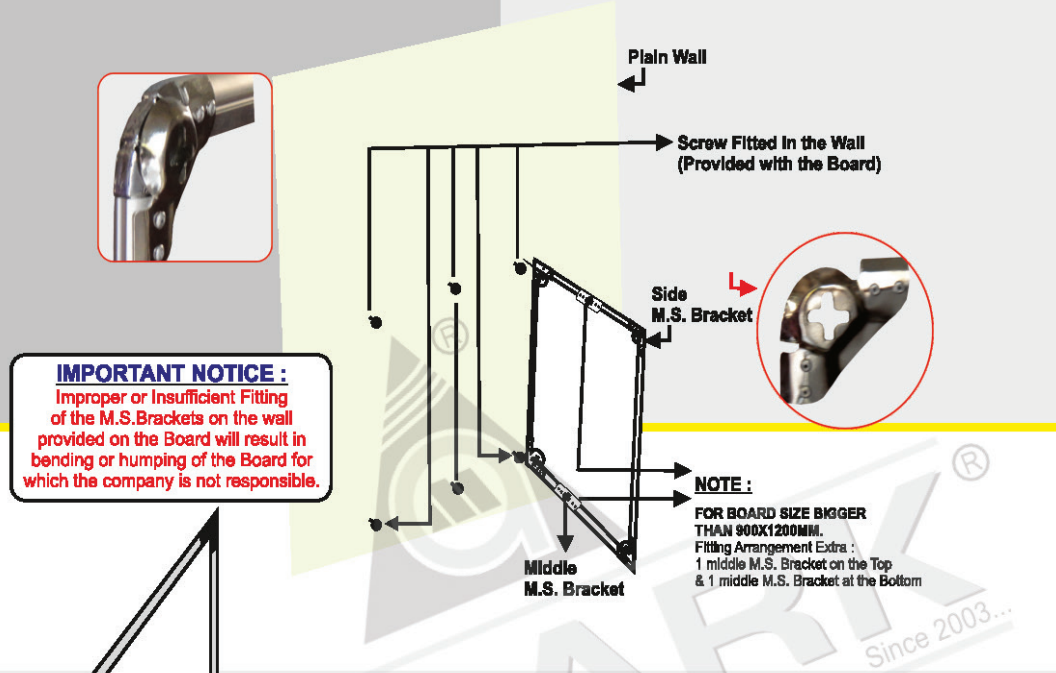

Line Diagram for fitting of plastic pen Tray on the Astel frame Board

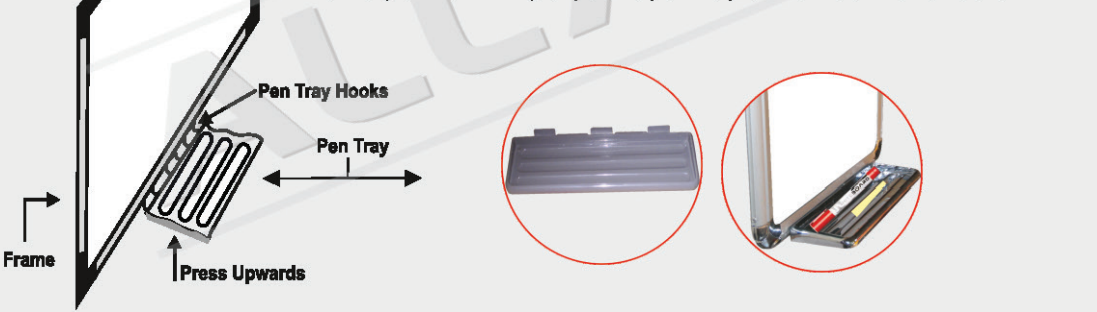

LINE DIAGRAM FOR MOUNTING OF THE BOARD ON THE WALL

DRY ERASE MARKERS / CHALKS

All dry marker can be used on White Writing Boards but for best performance use solvent based markers.

NOTE: Some type of chalk are incompatible with chalk boards and may scratch the surface due to rough particles.

WHITE BOARDS / CHALK BOARDS

- A. Before using your Magnetic White / Chalk Board for the first time remove the protective films from the surface.
- B. Spray the Board with any Dry Board cleaner and wipe with a soft cloth or duster.
- C. Rinse with clear water. This step is simple but very important.
- D. Wipe with Dry Cloth.

EVERY DAY CARE

If your Board is used daily full cleaning should be done regularly. More through cleaning may be required if texts are left on the board for more than 2 days

Periodic cleaning is recommended for problem free longevity of this Board.
A clean Board is a well prepared Board and a well prepared Board gives a well presented presentation.

DO NOT USE PERMANENT MARKERS

PERMANENT MARKERS INK CAN BE REMOVED BY ISOPROPYL ALCOHOL

How to Clean a Dry Erase Board

You can actually use a dry erase marker to remove permanent marker from your whiteboard!
This is a quick and easy trick to remove stains from Sharpies, pens, and other permanent writing tools.

If someone has accidentally used a permanent marker on your board, just follow these steps:

- Use a fresh dry erase marker to write over top of the stains, covering them completely.
- Wait a few seconds for the marker to dry.
- Wipe away all marks with a cloth or felt eraser.
- The dry erase ink will lift away the permanent ink.
- Other Methods to Clean a Whiteboard.
- Dry Erase marker writing on whiteboard.

If you need to clean your dry erase board in a hurry, there are two other methods you can use:

- Household Products
- Hand Sanitizer
- Rubbing Alcohol
- Non-acetone Nail Polish remover
- Peroxide
- Hair spray
- Vinegar
- WD-40

Follow these instructions using any of the liquid solvents above:

- Pour a small amount of liquid onto a sponge or soft cloth
- Wipe the entire surface of the board
- Wipe the board a second time using only water
- Dry the board completely
- Repeat the process if necessary
- Whiteboard Cleaner
- Cleaning your dry erase board with a whiteboard cleaner every 2 or 3 days will help to keep it looking its best.
- Cleaners come in spray bottles or convenient disposable wipes. Regularly cleaning the board ensures that your dry erase ink doesn't sit on the board for too long, which can cause stains.

You don't have to live with a messy whiteboard. Keeping the board clean ensures that your notes are legible and your ideas are well-communicated. Use any of our ideas to wipe your board clean for your next presentation.

